

PTDATA FOR WINDOWS

Post-Tensioning Design and Analysis Programs

THEORY MANUAL

Structural Data Incorporated

PMB 146, 16835 Algonquin Street

Huntington Beach, CA 92649

714/840-5570 – Fax 714/840-5058

© 2000

Table of Contents

Chapter 1 - Description

- 1.1 Analysis Method
- 1.2 Units
- 1.3 Sign Convention

Chapter 2 - Prestressed Concrete Freebody Diagrams

- 2.1 The Concrete-Only Freebody Diagram
- 2.2 The Concrete/Tendon Freebody Diagram
- 2.3 The Easy Way to Calculate Secondary Moments

Chapter 3 - Applied Loads

- 3.1 Uniform Load
- 3.2 Line Load
- 3.3 Point Load
- 3.4 Concentrated Moment
- 3.5 Wind Moment

Chapter 4 - Cross-Section Types

- 4.1 Section Identification
- 4.2 Development of Flexural Reinforcing (WARNING)

Chapter 5 - Tendon Profiles

- 5.1 Types 1 and 8 (Centerline Parabola)
- 5.2 Types 2 and 9 (Face-to-Face Parabola)
- 5.3 Types 3 and 12 (Compound Parabola)
- 5.4 Types 4 and 10 (Single-Point Centerline Harp)
- 5.5 Types 5 and 11 (Single-Point Face-to-Face Harp)
- 5.6 Type 6 (Double-Point Centerline Harp)
- 5.7 Type 7 (Double-Point Face-to-Face Harp)

Chapter 6 - Equivalent Loads

- 6.1 Equivalent Loads in the Constant Prestress Force Method
 - (a) Curvature Loads for Each Tendon Type
 - (b) *CGC* and *CGS* Discontinuities
 - (c) Tendon Force Discontinuities
 - (d) Equivalent Loads for Added Tendons
- 6.2 Equivalent Loads in the Variable Prestress Force Method

Chapter 7 - Flexural and Torsional Stiffnesses

- 7.1 Flexural Stiffness for Columns (Rigid or Equivalent Frame)
 - (a) Modeling of Top and Bottom Columns
- 7.2 Flexural Stiffness of Rigid Frame Beams
- 7.3 Equivalent Frame Geometry and Definitions
- 7.4 Flexural Stiffness of Equivalent Frame Beams

7.5 Stiffness of Equivalent Frame Torsional Members

- (a) The “Standard” Torsional Member
- (b) The Transverse Beam Torsional Member
- (c) An Adjustment in K_t for “Parallel” Beams

7.6 The “Equivalent” Column Stiffness K_{ec}

Chapter 8 - Frame Moments, Shears, and Design Points

8.1 User-Controlled Design Points

8.2 Program-Controlled Design Points

8.3 Moments

8.4 Shears

Chapter 9 - Design by PTData+

9.1 General Design Theory for Post-Tensioned Concrete

- (a) Flexural Strength
- (b) Cracking Moment
- (c) Arbitrary Minimums

1. One-Way Beams and Slabs

2. Two-Way Slabs

- (d) Shear Strength

9.2 The Computer-Generated “Automatic” Design

- (a) Special Conditions at Cantilevers

9.3 Iteration to the Final Design

Chapter 10 - Flexural Stresses

- 10.1 Concrete Flexural Stresses at Service Loads
- 10.2 Concrete Flexural Stresses at Transfer of Prestress

Chapter 11 - Flexural Strength

- 11.1 Strength Theory in Prestressed Concrete
- 11.2 The Precise Stress-Strain Method
- 11.3 The Simplified ACI Code Method
- 11.4 Strength Calculations in **PTData+**
 - (a) The Basic Cross-Section Geometry
 - (b) The Reinforcing Index
 - (c) How **PTData+** Calculates A_S and A'_S
 - 1. Sections Requiring Tension Steel Only
 - 2. Sections Requiring Tension and Compression Steel
 - (d) Ultimate Tendon Stress f_{ps}
 - 1. Unbonded Tendons
 - 2. Bonded Tendons

Chapter 12 - Inelastic Moment Redistribution

- 12.1 Inelastic Theory in Continuous Beams
- 12.2 Code Redistribution of Ultimate Moments ($1.4DL+1.7LL$)
 - (a) How the Redistribution is Done
- 12.3 Redistribution of $DL+LL/4$ Moments

Chapter 13 - Deflection

Chapter 14 - Shear Strength

14.1 Beam Shear

(a) Concrete Shear Strength

1. V_{cn} (ACI Equation 11-10)
2. V_{cw} (ACI Equation 11-13)
3. V_{ci} (ACI Equation 11-11)

(b) Reinforcement Shear Strength

(c) Minimums

(d) Maximum Stirrup Spacing

14.2 Punching Shear

(a) Shears and Moments

(b) Applied and Allowable Stresses on the Critical Punching Shear

Section

(c) Critical Punching Shear Section Dimensions

(d) Critical Punching Shear Section Properties

(e) Column and Slab Edge Relationships

(f) The “ d ” Dimension in Punching Shear Calculations

This page intentionally left blank

Notation

A	Cross-sectional concrete area
A_c	Cross-sectional concrete area of the critical punching shear section
A'_s	Cross-sectional area of unstressed longitudinal compression steel
A_{ps}	Cross-sectional area of prestressed steel
A_s	Cross-sectional area of unstressed longitudinal tension steel
A_v	Cross-sectional area of shear reinforcement (stirrups)
a	Tendon sag (the maximum offset from the chord, the line connecting the two highpoints in each span)
a_c	Depth of rectangular compression stress block at nominal strength
B, B_w	Minimum web width of a T-beam
B'	Width of rectangular concrete compression stress block at nominal strength
b_o	Perimeter of the critical punching shear section
C	Total compression force acting on freebody cross-section at nominal strength ($= C_c + C_s = T_p + T_s = T$)
C_c	Compression force acting on freebody cross-section resisted by concrete at nominal strength
CGC	Centroid of concrete cross-section
CGR	Center of gravity of unstressed steel
CGS	Center of gravity of prestressing steel
C_s	Compression force acting on freebody cross-section resisted by unstressed compression reinforcement at nominal strength ($= A'_s f_y$)
C_t	Constant used in the stiffness calculation for the torsional member in the equivalent frame method
c	Distance from extreme compression fiber to neutral axis
c_1	Column dimension parallel to beam span (c_{1L} at the left end of a span, c_{1R} at the right end of a span)
c_2	Column dimension perpendicular to beam span (c_{2L} at the left end of a span, c_{2R} at the right end of a span)

c_l	Distance from support centerline to high point tendon profile “bend” at the left end of the beam
c_r	Distance from support centerline to high point tendon profile “bend” at the right end of the beam
D	Dead load moment or shear at a design point
d	Distance from extreme compression fiber to the centroid of the resultant total tension force ($T_p + T_s$). In shear calculations only (Chapter 14) d need not be less than $0.8h$
d'_s	Distance from extreme compression fiber to centroid of unstressed compression steel A'_s
d_p	Distance from extreme compression fiber to centroid of prestressing steel A_{ps}
d_s	Distance from extreme compression fiber to centroid of unstressed tension steel
A_s	
E_b	Modulus of elasticity of beam concrete
E_c	Modulus of elasticity of column concrete
E_{ps}	Modulus of elasticity of prestressing steel
E_s	Modulus of elasticity of unstressed tension or compression steel
e	Eccentricity, distance between the CGS and the CGC
e_x	Horizontal distance from column centerline to centroid of the full critical punching shear section
e_y	Vertical distance from the datum line to centroid of the variable-stress sides of the critical punching shear section
F	Effective prestress force
$FLANGE$	Width of slab assumed effective in beam section properties
f	Flexural concrete stress
f'_c	Concrete compression strength at 28 days
f'_{ci}	Concrete compression strength at time of stressing
f_{dl}	Extreme fiber flexural tensile stress caused by unfactored dead load
f_{pc}	Average concrete compression F/A
f_{pe}	Extreme fiber flexural compressive stress caused by equivalent tendon loads at the fiber where tension is caused by applied gravity loads
f_{ps}	Stress in prestressing steel at nominal member strength (ultimate stress)
f_{pu}	Specified maximum tensile stress in prestressing steel

f_r	Modulus of rupture in concrete, the flexural tensile strength or the stress assumed to produce first cracking (normally $7.5f'_c$)
f_s	Stress in unstressed tensile steel at nominal strength (normally $=f_y$)
f_v	Combined shear stress acting on the punching shear critical section due to direct shear and a portion of the unbalanced moment
f_y	Yield stress of unstressed steel
H_w	For a transverse equivalent frame beam, the dimension from the lowest slab soffit on either side of the joint to the soffit of the transverse beam
h	Total member depth
I	Moment of inertia
I_s	Moment of inertia of the slab portion <u>only</u> of a flanged beam section including the full slab tributary and excluding any portion of the beam web extending below the lowest slab soffit (used in the equivalent frame method).
I_{sb}	Moment of inertia of an entire flanged beam section including the full slab tributary and the entire beam web (used in the equivalent frame method).
J_c	“Polar” moment of inertia of the critical punching shear section about a horizontal centroidal axis perpendicular to the plane of the equivalent frame
L	Beam span between support centerlines
L^+	Most positive live load moment or shear at a design point
L^-	Most negative live load moment or shear at a design point
L_{2L}	The dimension from the centerline of the equivalent frame beam to the centerline of the adjacent equivalent frame beam to its left , looking towards the left (towards Joint 1)
L_{2R}	The dimension from the centerline of the equivalent frame beam to the centerline of the adjacent equivalent frame beam to its right , looking towards the left (towards Joint 1)
L_c	Column length from centerline of beam depth to point of fixity or pin at far end
L_{clr}	Beam clearspan between support faces
M_2	Secondary moment
M_{bal}	Balanced or equivalent load moment
M_{cmax}	Maximum moment permissible on any cross-section without compression reinforcement
M_{cr}	Moment <i>in excess</i> of the unfactored dead load moment which produces an extreme fiber tensile stress of $6f'_c$ (used in beam shear calculations for V_{ci})

M_{design}	$M_u + M_2$ (the <i>demand</i> moment)
M_{dl}	Unfactored dead load moment
M_{equiv}	Moment which equilibrates the tendon balanced, or equivalent, loads only (not including the reactions to those loads, which are called the secondary reactions)
M_f	Portion of the total unbalanced moment M_u at a joint which is transferred by direct flexure between slab and column
M_{fr}	Moment which produces a flexural tensile stress equal to the modulus of rupture f_r (the cracking moment referenced in ACI 318 Section 18.8.3)
M_{ll}	Unfactored live load moment
M_{max}	$M_u - M_{dl}$
M_n	Nominal moment capacity (without ϕ factor)
ϕM_n	Useable moment capacity
M_{net}	$M_{tl} + M_{bal}$
M_{tl}	$M_{dl} + M_{ll}$
M_u	Applied moment caused by factored dead and live loads
M_v	Portion of the total unbalanced moment M_u at a joint which must be transferred by eccentric shear stresses on the critical punching shear section
M_{wind}	Unfactored wind moment
N	Total number of segments into which each span is divided, each representing a potentially different cross-section
P	Number of equal spaces into which each clearspan is divided, with all design parameters (moments, shears, stresses, deflections, reinforcing, etc.) calculated at each end of each space
R_2	Secondary reaction
$\%R$	Maximum permissible percentage of inelastic negative moment redistribution
S	Number of spans in the frame, not counting cantilevers
S_m	Section modulus
S_{mb}	Section modulus at the bottom beam fiber
S_{mt}	Section modulus at the top beam fiber
s	Stirrup spacing measured along length of beam
T	Total tension force acting on freebody cross-section at nominal strength (= $T_p + T_s = C$)

T_p	$A_{ps}f_{ps}$, tensile force in prestressing steel at nominal member strength (the ultimate prestress force)
$TRIB$	Tributary, the perpendicular distance supported by a frame beam ($TRIBL + TRIBR$)
$TRIBL$	Dimension from the centerline of a beam to a point midway to the adjacent beam (or support) to its left , looking towards the left (towards Joint 1)
$TRIBR$	Dimension from the centerline of a beam to a point midway to the adjacent beam (or support) to its right , looking towards the left (towards Joint 1)
T_s	$A_s f_y$, tensile force in unstressed tension steel (normally rebar) at nominal member strength (the ultimate rebar tensile force)
t	Slab thickness
U	Required flexural or shear strength at a design point
V_c	Controlling nominal concrete shear strength (determined from V_{cn} , V_{ci} , V_{cw})
V_{ci}	Nominal shear strength for “inclined cracking” type of shear failure. (ACI 318 Eqn. 11-11)
V_{cn}	Nominal concrete shear strength (ACI 318 Eqn. 11-10). Can be used for V_c in lieu of V_{ci} or V_{cw}
V_{cw}	Nominal shear strength for “web cracking” type of shear failure (ACI 318 Eqn. 11-13)
V_{dl}	Unfactored dead load shear
V_i	$V_u - V_{dl}$
V_{ll}	Unfactored live load shear
V_n	Nominal shear capacity $V_c + V_s$ (without ϕ factor)
ϕV_n	Useable shear capacity
V_p	Vertical component of prestress force (the shear “carried” by the tendons)
V_s	Nominal shear strength of shear reinforcement (stirrups)
V_{tl}	$V_{dl} + V_{ll}$
V_u	Applied factored total load shear (the demand shear)
v_c	Allowable combined shear stress acting on the critical punching shear section
V_{wind}	Unfactored wind shear
W	Wind moment or shear
w_{bal}, w_p	Tendon balanced, or equivalent, load
w_{dl}	Unfactored dead load

w_{ll}	Unfactored live load
w_{net}	$w_{tl} + w_{bal}$
w_{tl}	$w_{dl} + w_{ll}$
w_u	Factored dead plus live load
$x_{L,R}$	Distance from the centroid of the critical punching shear section to its left and right faces
$X_{L,R}$	Distance from the centroid of the lower column to the left and right faces of the critical punching shear section
Y_l	Distance from datum line to <i>CGS</i> at left end beam highpoint
Y_m	Distance from datum line to <i>CGS</i> at a lowpoint
Y_r	Distance from datum line to <i>CGS</i> at right end beam highpoint
Y_{ref}	Distance from datum line to top of beam
Y_{tb}	For a transverse equivalent frame beam, the vertical distance from the datum line to the soffit of the transverse beam
y_t	Distance from concrete centroid to the extreme fiber where tension is caused by applied gravity loads
α_s	A term used in determining v_c . $\alpha_s = 40$ for interior columns, 30 for edge or edge parallel columns, and 20 for corner columns
β_l	Factor which varies with concrete strength f'_c : β_l is 0.85 for strengths up to and including 4000 psi, then reduces continuously at a rate of 0.05 for each 1000 psi of strength in excess of 4000 psi down to a minimum of 0.65.
β_c	Ratio of long side to short side of a rectangular column ($\beta_c = 1$ for round columns)
γ_r	A factor used in the calculation of fps for bonded tendons, 0.40 for stress-relieved steel, 0.28 for low-relaxation steel
γ_v	The decimal fraction of the total unbalanced moment at any joint of a two-way system which must be transferred from slab to column by eccentric shear stresses on the critical punching shear section
ϕ	Capacity reduction factor (0.9 for flexure, 0.85 for shear)
ρ	Reinforcing steel ratio = $A_s / B'd_s$
ρ_b	Balanced reinforcing steel ratio = $0.85\beta_l f'_c / f_y [87000 / (87000 + f_y)]$
ω	Reinforcing index $(T_p + T_s - C_s) / (B'd_p f'_c)$

Chapter One

Description

PTData+ is a computer program for the design and analysis of linear post-tensioned concrete frames. The maximum number of spans in the frame is 15 plus a cantilever at either or both ends. The term “span” herein is defined as a length of beam or slab supported at both ends, as opposed to a cantilever which is supported at one end only. Spans are numbered consecutively from left to right starting with 1 and ending with S , where S is the total number of spans excluding cantilevers. A left cantilever is identified as Span 0 and a right cantilever is identified as Span $S+1$. A maximum of 20 superimposed dead or live loads may be applied in any span or cantilever. The applied loads can be uniform “line” loads over all or part of a span or cantilever, point loads, concentrated moments, or wind moments, moments induced into the frame by lateral wind loads. Each span or cantilever can be non-prismatic between supports, divided into a maximum of 20 variable-length segments, each with one of a library of available cross-sectional “types”. Each span or cantilever can contain one of 7 different tendon profiles (5 for cantilevers), including simple parabolas, compound parabolas, single point harps, and double point harps. The above span, load and section criteria are programmed limits assuming unlimited memory (RAM). The actual maximum values of spans, loads per span, and sections per span may be reduced depending on the actual RAM memory available. Figure 1.1 shows the arrangement and identification of spans, beams, joints and columns in the frame.

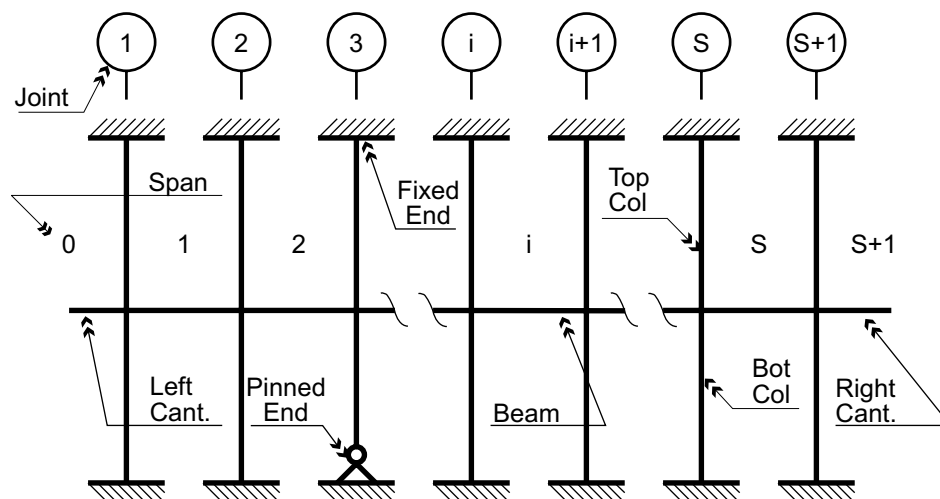

Figure 1.1 - Span and Joint Identification

Throughout this document the term “beam” will be used to address the horizontal frame members, regardless of whether they are actually beams, girders, or slabs in common engineering vernacular.

1.1 - Analysis Method

PTData+ uses a rigid frame method of analysis for one-way beams and slabs, and the ACI Building Code “equivalent frame” method for two-way systems. Frame moments in both methods are calculated using the stiffness matrix method. The frame is planar (two-dimensional) and consists of beams and columns rigidly connected in the case of one-way members, and in the equivalent frame method, beams and columns connected by torsional members or “springs”. Each joint can have a column above, a column below, or both. Far-end column fixity can be either pinned or fixed. Sidesway and axial member deformation are not considered.

Design and/or analysis parameters are calculated at a user-specified number of points in each span or cantilever, plus the following points which are always present:

- At $h/2$ from each column centerline where h is the slab or beam depth adjacent to each support. These points are included because they are the points of critical shear in most post-tensioned beams (beams which produce compression in their supports.)
- At both sides of each point where a change in slab or beam cross-section occurs.

The design or analysis can be made using a constant force approach, in which the effective prestress force is assumed to be constant throughout the member, or a variable force approach which considers the effects of stressing locations, tendon friction, and longterm losses at each point. In the variable force approach, 12 different tendon stressing patterns can be considered, including up to 2 interior stressing points. The supported stressing patterns are shown in Figure 1.2. In addition to the continuous tendons shown in Figure 1.2, the variable force mode supports any number of added tendons in each pattern. The added tendon can be located with its stressing end coincident with any stressing end shown in the twelve patterns, and its dead-end located at any other point in the frame (consistent, of course, with the direction of the stressing end.)

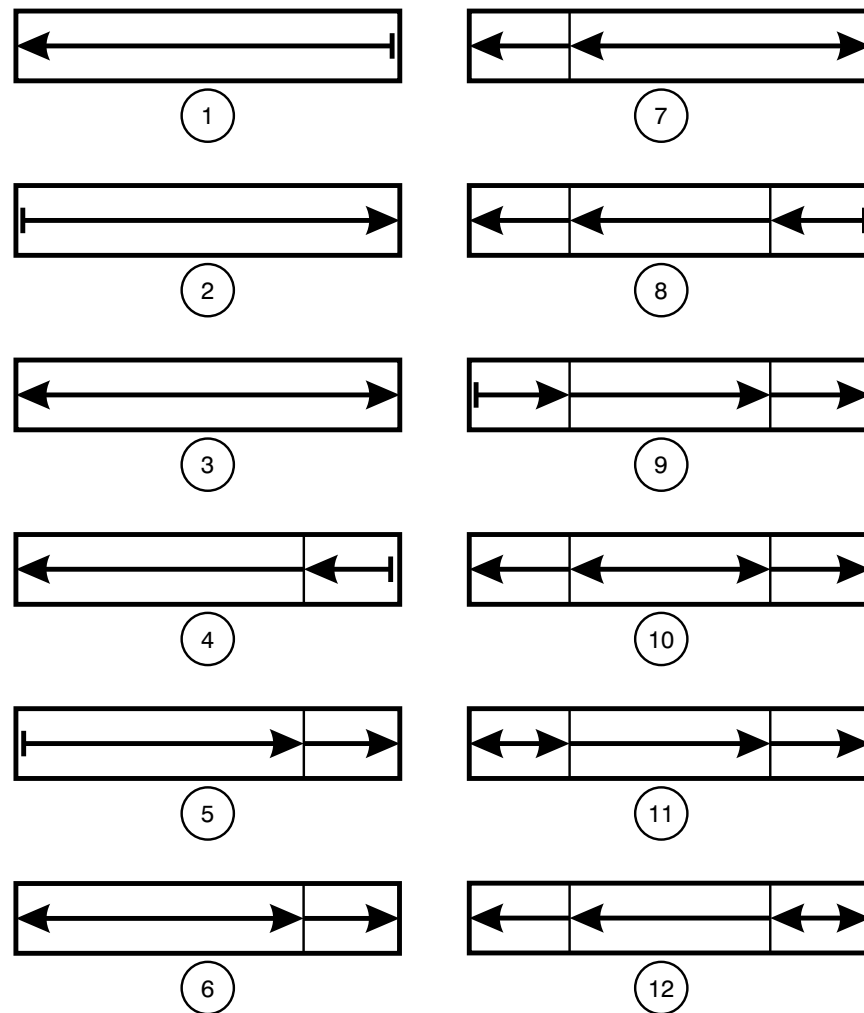

Figure 1.2 - Stressing Options - Variable Force Mode

1.2 - Units

PTData+ is unit-specific, which means that each parameter must be entered with specific units, and the output is presented in specific units. The units in **PTData+** are, in the author's opinion, those most commonly used by structural engineers for each program parameter and are identified clearly in input and output routines. Loads are expressed in kips and feet, moments in kip-feet, stresses in kips per square inch, deflections in inches. Spans, tributaries, and column lengths are in feet and all cross-section dimensions are in inches except for T-beam flange widths, which are in feet.

1.3 - Sign Conventions

The following sign conventions are followed in **PTData+**:

- Internal Bending Moments in Beams - Positive causes tension on the bottom beam fiber, negative causes tension on the top fiber.
- Internal Bending Moments in Columns - Clockwise positive, counterclockwise negative, acting on the top of the bottom column or the bottom of the top column.
- Flexural Stresses - Tensile stresses are positive, compressive stresses are negative.
- Deflection - Down (sag) is positive, up (camber) is negative.
- Shear - An upward load to the left of a section causes positive shear at the section.
- Applied Loads - Loads acting down are positive, loads acting up are negative. Concentrated moments are clockwise positive, counterclockwise negative. Applied wind moments follow internal beam moment conventions (positive causes tension in the bottom beam fibers, negative causes tension in the top beam fibers).

Chapter Two

Concrete Freebody Diagrams

The design or analysis of indeterminate prestressed concrete structures uses three unique freebody diagrams for determining the elastic effects of the internal prestressing force. The first, called the “concrete-only” freebody, consists of the frame concrete *only*, with the prestressing tendons removed and replaced with the loads they exert on the concrete. The second, called the “tendon only” freebody, consists of the prestressed tendon only, isolated with the loads required to equilibrate it in its specific shape. The third is the combination of the first two, the complete concrete/tendon freebody. Understanding the statics of these three freebodies is critical to the analysis and design of post-tensioned concrete structures.

To demonstrate the use of the three freebody diagrams, the two-span indeterminate prestressed beam shown in Figure 2.1 will be used as an example. The beam has applied external unfactored dead and live loads w_{TL} , and factored dead and live load w_u , both of which include the weight of the beam itself. While this is a simple example of an indeterminate prestressed concrete beam, the principles derived are general and will apply at any level of complexity.

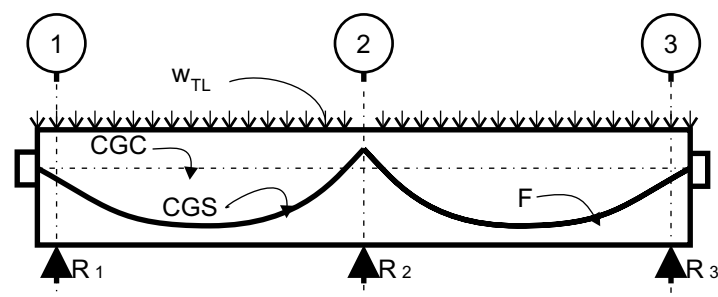

Figure 2.1 - Indeterminate Post-tensioned Beam

2.1 - The Concrete-Only Freebody Diagram

If the prestressed tendon is (mentally) removed from the beam in Figure 2.1, and the externally applied loads w_{TL} temporarily ignored, the remaining portion of the beam (the concrete) would look like Figure 2.2(a). The loads F , P_1 through P_3 , and w_p are a *set* of loads applied to the concrete by the tendon. The tendon itself is isolated in Figure 2.2(b), equilibrated in its precise profile with a *set* of loads equal and opposite to those acting on the concrete in Figure 2.2(a). It is convenient to assume that the tendon force F is applied at the center of gravity of the concrete section. If in reality it is not applied there, it is transformed to that position with the addition of an appropriate moment acting at the ends of the beam.

The set of loads applied to the concrete by the tendon and vice versa are known as the “equivalent” loads. They are a function only of the tendon force and profile and are completely general in nature, i.e., the loads P_1 through P_3 are not necessarily applied

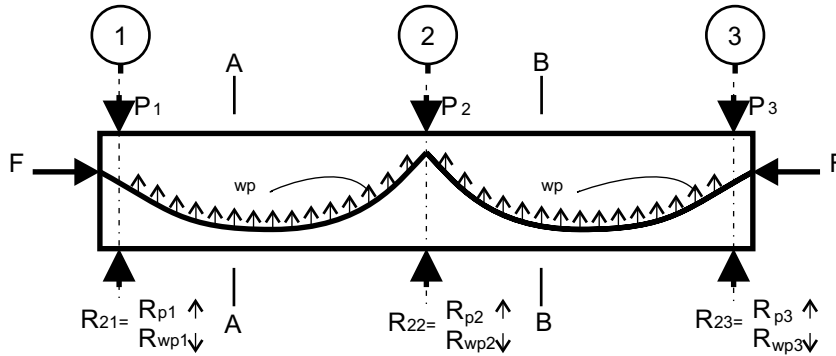

Figure 2.2(a) - Concrete-only Freebody Diagram

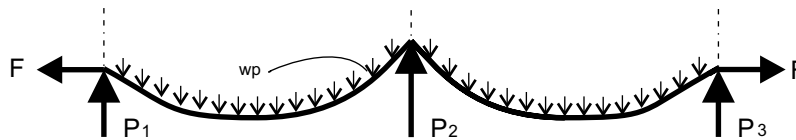

Figure 2.2(b) - Tendon-only Freebody Diagram

directly into the supports and w_p is not necessarily the same in each span, nor is it necessarily a uniform load as shown. The only requirement for the equivalent loads is that they be in equilibrium with themselves - which should be obvious from Figure 2.2(b) where the equivalent loads must equilibrate the tendon. The loads are shown the way they are in Figure 2.2 purely for convenience (they are a simple and recognizable set of equivalent loads) but it is emphasized that they are in fact any general set of loads in any shape or direction which will equilibrate the tendon in its given profile within the concrete.

The equivalent loads produce a set of reactions acting on the concrete-only freebody in Figure 2.2(a). It is important to distinguish between the reactions to the equivalent loads and the equivalent loads themselves, as is done in Figure 2.2(a). The reactions to the equivalent loads are called the “secondary” reactions (R_2) and are designated R_{21} , R_{22} , and R_{23} at supports 1 through 3 respectively. Since the set of equivalent loads are in equilibrium *with themselves* (they equilibrate the tendon), the set of secondary reactions acting on the concrete-only freebody must also be in equilibrium *with themselves*. Since the equivalent loads are in equilibrium, some are applied upwards (w_p) and some downward (P_1 - P_3). The secondary reactions are shown in Figure 2.2(a) separated into two components, one (R_{p1} , R_{p2} and R_{p3}) which equilibrates

the downward equivalent loads P_1 , P_2 , and P_3 , and one (R_{wp1} , R_{wp2} , and R_{wp3}) which equilibrates the upward equivalent loads w_p . The reactions to the applied loads are indeterminate (3 reactions, 2 equations of equilibrium), so the reactions to the upward applied loads (R_{wpi}) at support i will not, in general, be equal to the reactions to the downward applied loads (R_{pi}) at support i . The secondary reactions will, in general, be non-zero, even though there are no externally applied loads and the beam is weightless.

For a unique type of tendon profile, called “concordant”, the secondary reactions in an indeterminate prestressed beam will be zero. In a concordant tendon the eccentricity e is at all points proportional to the moment at the same point in any real elastic moment diagram for the beam, i.e., any moment diagram consistent with zero deflection at all supports. Concordant tendon profiles normally do not result in full available sags and therefore have no application in practice, although they are inevitably discussed at great length in prestressed concrete textbooks.

Secondary reactions (and therefore moments) are always zero in determinate beams. Reactions in determinate beams can be calculated with equations of statics alone. All determinate beams have two reactions which can be solved with two equations of

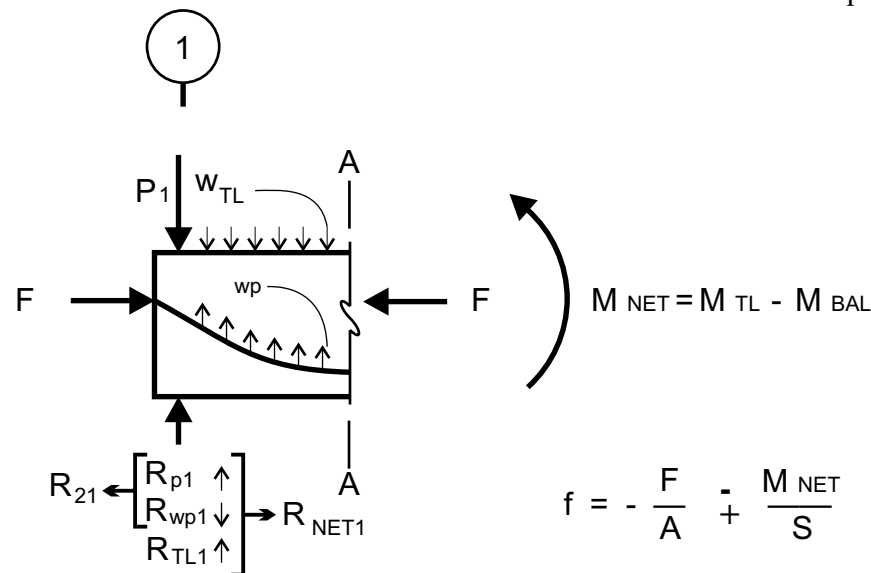

Figure 2.3 - Partial Concrete-only Freebody Diagram

equilibrium ($F=0$ and $M=0$). If the beam is weightless the only possible solution for the two reactions is for each of them to be zero.

To calculate concrete flexural stresses at a particular point $A-A$ in the prestressed beam using the concrete-only freebody, cut a section at that point as in Figure 2.3, and apply the appropriate external dead and live loads w_{tl} . The portion of the beam to the

right or left of section $A-A$ is isolated as a freebody (to the left in this case). The beam has flexural stiffness, thus there is a moment M_{net} acting at $A-A$ which equilibrates all the loads and reactions to the left (or right) of section $A-A$. M_{net} is the algebraic sum of the moment M_{tl} caused by total loads and their reactions (w_{tl} and R_{tl} in Figure 2.3) and M_{bal} , the moment caused by equivalent loads and their reactions (w_p , P_i , R_{pi} and R_{wpi} in Figure 2.3). The concrete flexural stresses f can be calculated at section $A-A$ using the simple “column” formula:

$$f = -\frac{F}{A} \pm \frac{M_{net}}{S_m} \quad \text{(Eqn. 2-1)}$$

The equivalent load method described above for calculating flexural concrete stresses results in substantial calculation efficiencies since the physical location of the tendon **need not be known** at section $A-A$. In the general case where the downward loads P_i are not applied directly into the supports, the reaction R_{pi} is not equal to P_i and the value of the downward applied loads P_i must be known. However in the special case where the downward applied loads P_i **are** applied directly into the supports, which occurs in many commonly assumed tendon profiles, the reaction R_{pi} at each support i is equal to the applied load P_i at that support and the two cancel each other. In this special case it is **not necessary** to know the values of the downward applied loads P_i . This results in additional efficiencies in the calculation of flexural concrete stresses in some indeterminate prestressed concrete beams.

2.2 - The Concrete/Tendon Freebody Diagram

The concrete/tendon freebody is created when the two freebodies shown in Figure 2.2 are combined (the tendon is put back inside the concrete). When this is done, the concrete/tendon freebody appears as in Figure 2.4(a). Note that the set of equivalent loads acting on the tendon cancel the set acting on the concrete and therefore the freebody has no applied loads acting (it is weightless, with the concrete load included in w_{tl}). The secondary reactions R_{2i} , however, **do not** disappear and are in fact present in the weightless freebody. They are shown all acting up in Figure 2.4(a) however since they must be in static equilibrium, some actually act up and some down. The secondary reactions produce moments in this concrete/tendon freebody, called “secondary moments”. Since these secondary moments are produced **only** by external “secondary” reactions, secondary moment diagrams are **always** straight lines between supports.

The concrete/tendon freebody can be used to calculate concrete flexural stresses. If stresses are desired at a point $A-A$ between grids 1 and 2 in the beam of Figure 2.4(a), the portion of the beam to the left of $A-A$ can be isolated as a freebody as shown in Figure 2.5(a). In this Figure the external total load w_{tl} has been added along with its reaction R_{tl} at support 1. For horizontal equilibrium the compression force in the concrete C must be located coincident with the tension force T in the steel. In Figure

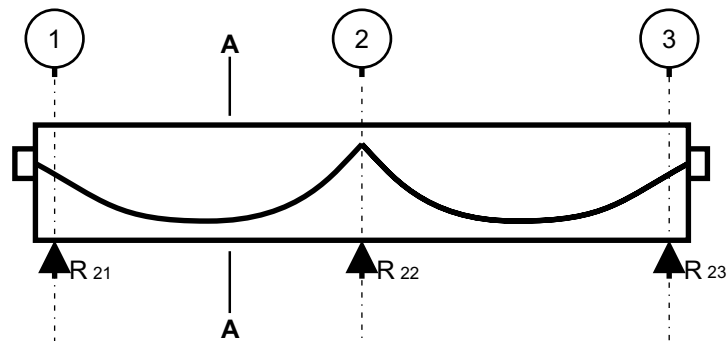

Figure 2.4(A) - Concrete/Tendon Freebody (Weightless Beam)

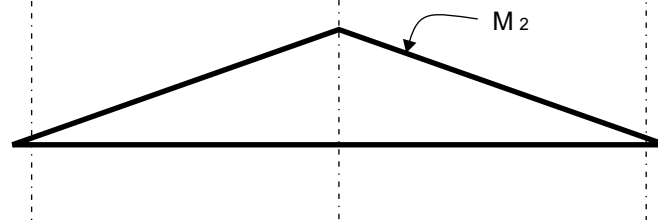

Figure 2.4(B) - Secondary Moment Diagram

Figure 2.4 - Secondary Reactions and Moments

2.5(b) C has been moved a distance e to the CGC , requiring the addition of a moment Fe on the section. The moment M_{tI} equilibrates the total load w_{tI} and its reaction R_{tI} and M_2 , the secondary moment, equilibrates the secondary reaction R_{2I} . With the forces acting on the concrete section $A-A$ in Figure 2.5(b) the general equation for concrete flexural stresses in the concrete/tendon freebody can be derived:

$$f = -\frac{F}{A} \pm \frac{M_{tI} + M_2 + Fe}{S_m} \quad (\text{Eqn. 2.2})$$

The computational effort in using Eqn. 2.2 is substantial since not only must the secondary moment M_2 be specifically known at each point, but so must be e , the physical location of the tendon. For these reasons, **PTData+** uses the concrete-only freebody for bending stress calculations.

The concrete/tendon freebody, however, is the only freebody which *can* be used to calculate flexural strength in prestressed concrete members. Flexural strength theory in concrete assumes that the strength of a cross-section is equal to a tension-compression couple with compression in the concrete and tension in the rein-

forcement (the stressed tendon and any unstressed reinforcement present). The concrete/tendon freebody is the only freebody which contains a tendon, therefore it **only** can be used for strength calculations.

To analyze the strength of a cross-section $A-A$ in the example beam, apply the ultimate (factored) load to the beam, cut the beam at Section $A-A$ and, as in the concrete-only freebody, determine the forces acting at section $A-A$ which equilibrate the portion of the beam to either side, in this case the left side. This is shown in Figure

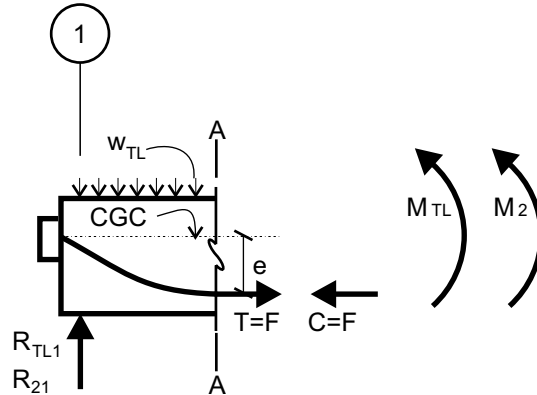

Figure 2.5(a) - Partial Concrete/Tendon Freebody

2.6, where the design ultimate moment M_{design} is the sum of M_u , the moment produced by the factored load and its reactions (w_u and R_{u1} in Figure 2.6) and M_2 , the secondary moment produced by the secondary reaction R_{21} . Horizontal equilibrium is provided by the concrete compression force C which is equal to the prestress force F , and the flexural strength, or capacity, of the section is provided by separating C and F by a distance $y = M_{design} / F$ without exceeding permissible stresses in either the concrete or the steel (see Chapter 11).

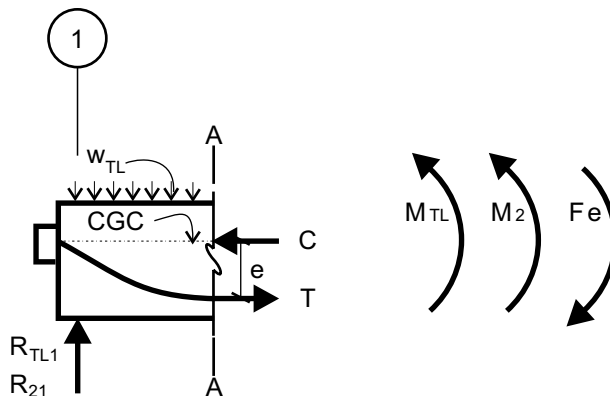

Figure 2.5(b) - Partial Concrete/Tendon Freebody

2.3 - The Easy Way to Calculate Secondary Moments

Flexural strength calculations in indeterminate prestressed concrete beams require

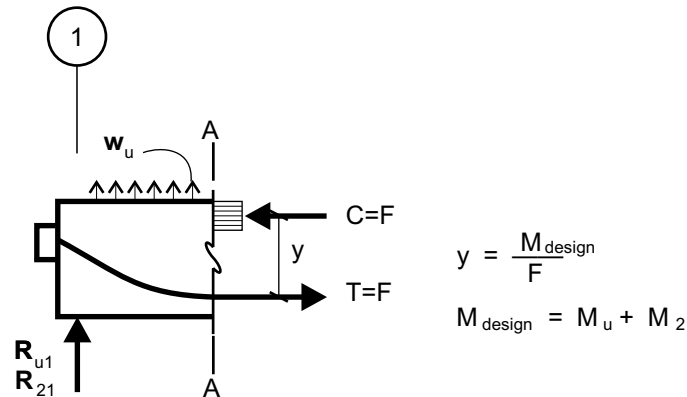

Figure 2.6 - Partial Concrete/Tendon Freebody

that the secondary moment M_2 be known at each point in the beam. The secondary moments can be calculated by applying the equivalent loads to the beam, calculating the reactions to those equivalent loads, as discussed in Section 2.1, and then determining the moments produced by those reactions. This is a lengthy mathematical process, even for simple tendon profiles. A more efficient way is to derive the secondary moment directly, as follows.

Suppose the secondary moment is desired at a point $B-B$ in the example beam of Figure 2.2 between grid lines 2 and 3. Cut a section through the freebody of Figure 2.2(a) at that point and isolate the portion of the beam to the left as shown in Figure 2.7(a). The total moment M_{bal} acting at $B-B$ can be expressed as the sum of the moments M_{equiv} caused by the equivalent loads alone (w_p , P_1 , and P_2), and M_2 caused by the reactions alone (the secondary reactions R_{21} and R_{22}). Therefore:

$$M_{bal} = M_{equiv} + M_2 \quad \text{(Eqn. 2-3)}$$

Next, cut a section through the same point in the isolated tendon shown in Figure 2.2(b). The portion of the tendon to the left of $B-B$ is shown in Figure 2.7(b). The tendon has negligible flexural stiffness, so the moment acting on it at $B-B$ is zero. Taking moments about point o , which is on the CGC , and recognizing that the loads w_p , P_1 , and P_2 are the same set of equivalent loads applied in Figure 2.7(a) but in opposite sense, we find:

$$Fe = M_{equiv} \quad \text{(Eqn. 2-4)}$$

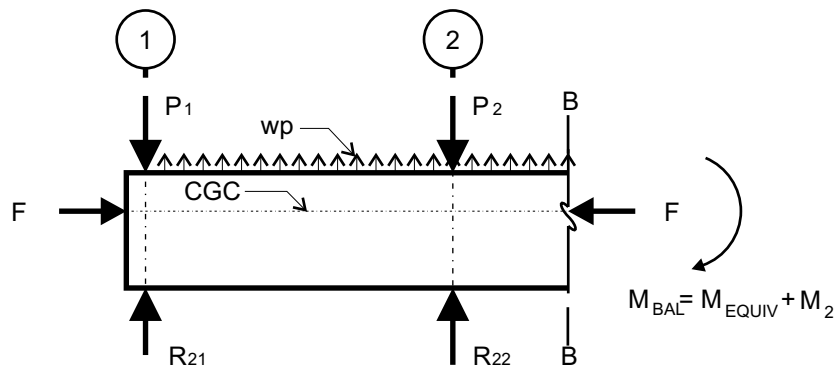

Figure 2.7(a) - Concrete Only

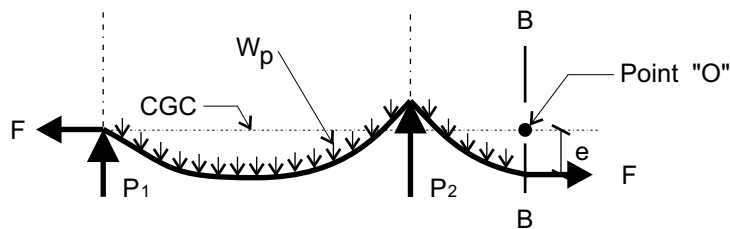

Figure 2.7(b) - Tendon Only

Figure 2.7 - Derivation of Secondary Moment M_2

where e is the distance between the CGC and the CGS at point $B-B$. Combining Equations 2-3 and 2-4 and eliminating the term M_{equiv} results in the following expression for M_2 :

$$M_2 = M_{bal} - Fe \quad \text{(Eqn. 2-5)}$$

which **PTData+** uses for calculating secondary moments.

Chapter Three Applied Loads

Five types of superimposed loads may be applied to the frame beams (see Figure 3.1):

3.1 - Uniform Load (U)

A uniform load in kips per square foot acting over the entire tributary of the beam between any two points along the span. Note that the starting and ending points of the load are both measured from the left support centerline, except in a left cantilever where they are measured from the right support centerline. The program converts the uniform load into a line load by multiplying the uniform load by the appropriate tributary (which may change within the extent of the load.)

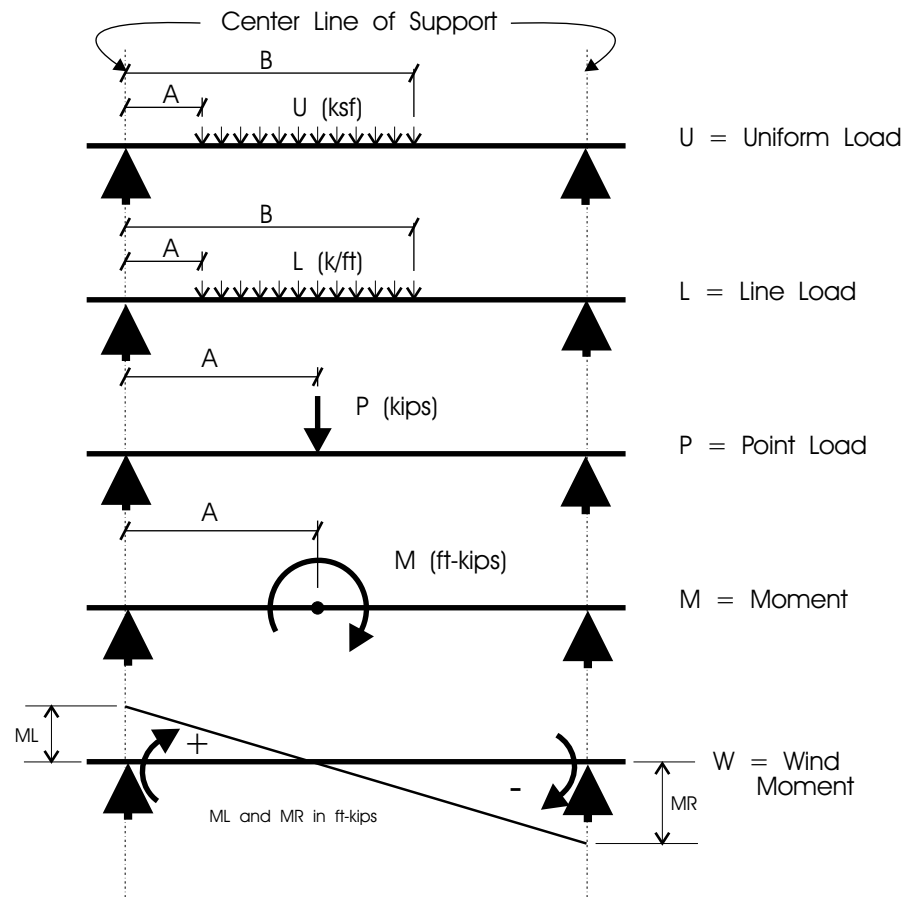

Figure 3.1 - Applied Loads

3.2 - Line Load (L)

A line load in kips per foot acting between any two points along the span. The starting and ending points of line loads are measured from the left support centerline, except in a left cantilever where they are measured from the right support centerline.

3.3 - Point Load (P)

A concentrated load in kips applied at a point A measured from the left support centerline, except in a left cantilever where it is measured from the right support centerline.

3.4 - Concentrated Moment (M)

A concentrated moment in kip-feet applied at a point A measured from the left support centerline, except in a left cantilever where it is measured from the right support centerline.

3.5 - Wind Moment (W)

A set of *two* internal beam moments in kip-feet, one acting at each end of the beam, caused by lateral wind loads. Wind moments are assumed to vary linearly between beam ends. Normally these moments will be obtained from a separate frame analysis for wind loads only. The signs of the input wind moments must be consistent with *one* direction of applied wind loads throughout the frame (either direction).

PTData+ knows these moments are reversible and will consider both directions of applied wind loads in its analysis.

In Figure 3.1 all of the loads are shown as positive, except the wind moments. Wind moments usually reverse in sign from one end of the beam to the other, thus the wind moments in Figure 3.1 are shown in this case positive at the left end of the beam, negative at the right end. Each load (except wind moments) can have a dead load part and a live load part, acting at the same load location. These superimposed loads are in addition to the concrete dead load, which is automatically calculated by the program using input geometry and concrete unit weight. A maximum of 20 superimposed loads may be applied in each span or cantilever, depending on memory availability.

Chapter Four Cross-Section Types

PTData+ supports a library of cross-section types which is shown in Figure 4.1. Variations in the vertical location of both tops and bottoms of members are supported. This is accomplished by defining the dimension between the topmost point in each section type and a horizontal datum line which is constant throughout the frame. This dimension is called Y_{ref} and is shown in Figure 4.1 for all of the section types. The datum line can be anywhere, however the following sign convention is observed: Y_{ref}

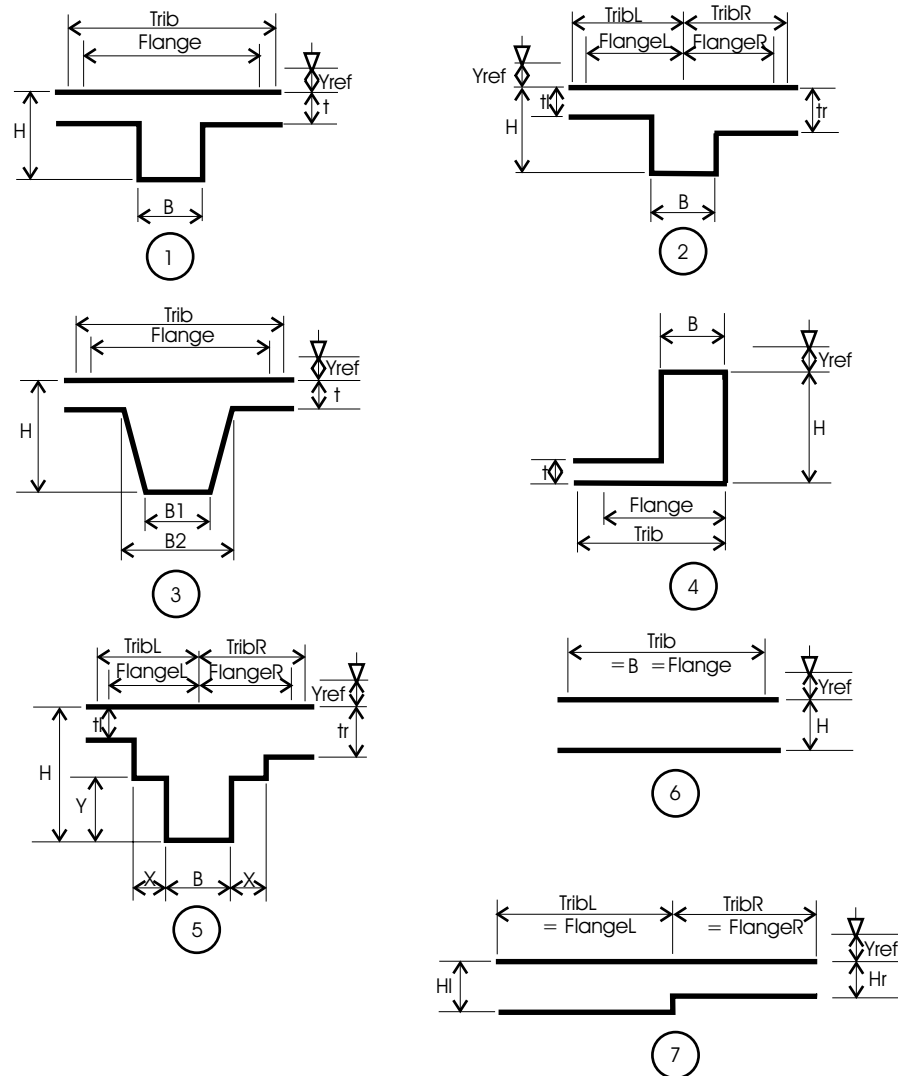

Figure 4.1 - Beam Types

is positive if the top of the member is below the datum line, negative if it is above the datum line. A convenient way to locate the datum line is at the top of the highest section in the frame. In that case, Y_{ref} is zero for the highest member and positive for other sections. In Figure 4.1 all Y_{ref} dimensions are shown positive. Other program parameters are also measured from the datum line, such as the CGC (center of gravity of the concrete cross section) and the CGS (center of gravity of the prestressing steel).

4.1 - Section Identification

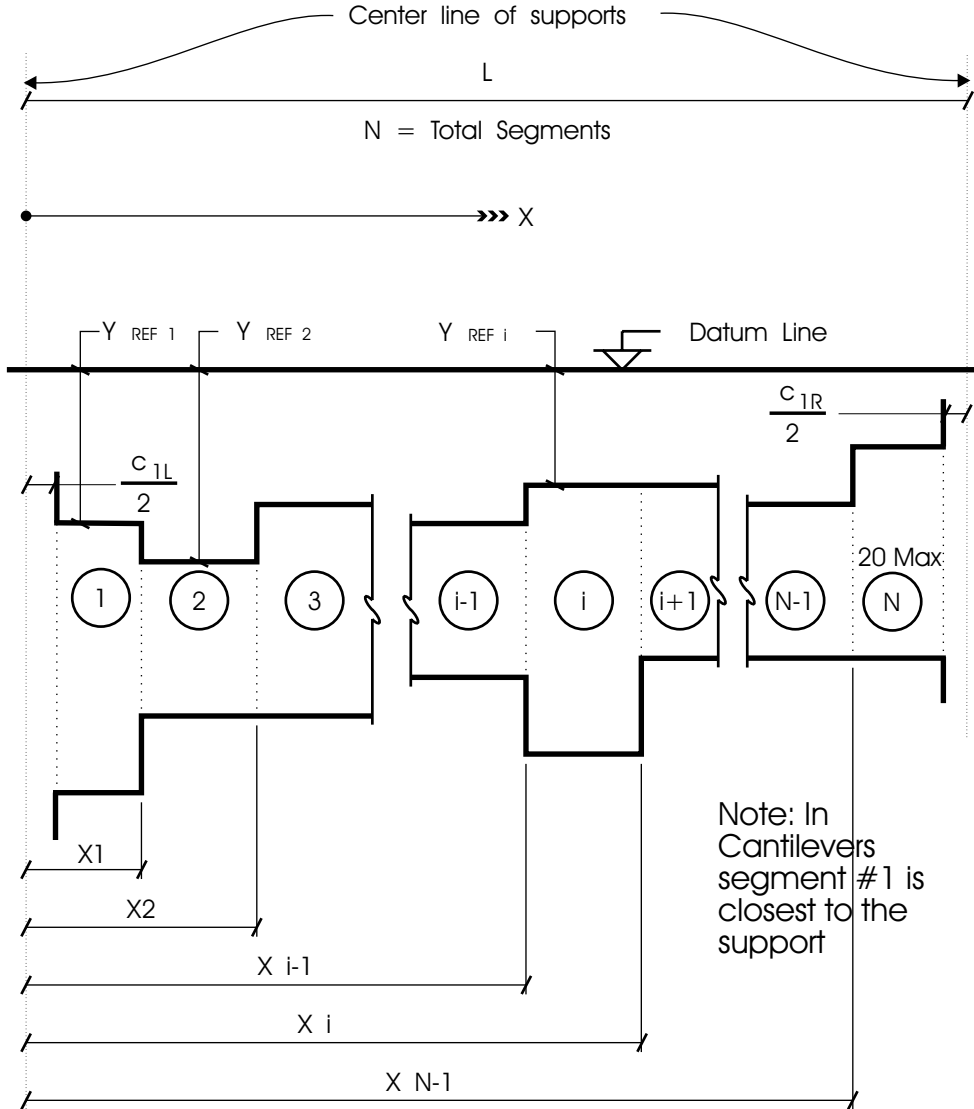

Figure 4.2 - Beam Segment Identification

Figure 4.2 shows the method used for identifying the segments which can have different cross-sections and their locations within each span. Note that the segments are numbered consecutively from left to right (right to left in a left cantilever) and all sec-

tion change locations (segment boundaries) are dimensioned from the left support centerline (right support centerline in a left cantilever.) There can be a maximum of 20 different section segments in each span or cantilever depending on RAM availability. Note carefully that the left end of Segment 1 is at the *face* of the left column and the right end of Segment *N* is at the *face* of the right column. The beam properties between the centerline of the column and the face of the column are not controllable by the user. They are defined in Chapter 7 and are different for rigid frames and for equivalent frames.

4.2 - Development of Flexural Reinforcing (WARNING)

The user is cautioned to carefully investigate the development of flexural reinforcement at points of cross section change. **PTData+** will accurately calculate the required amount of flexural reinforcement on either side of the section change, but it

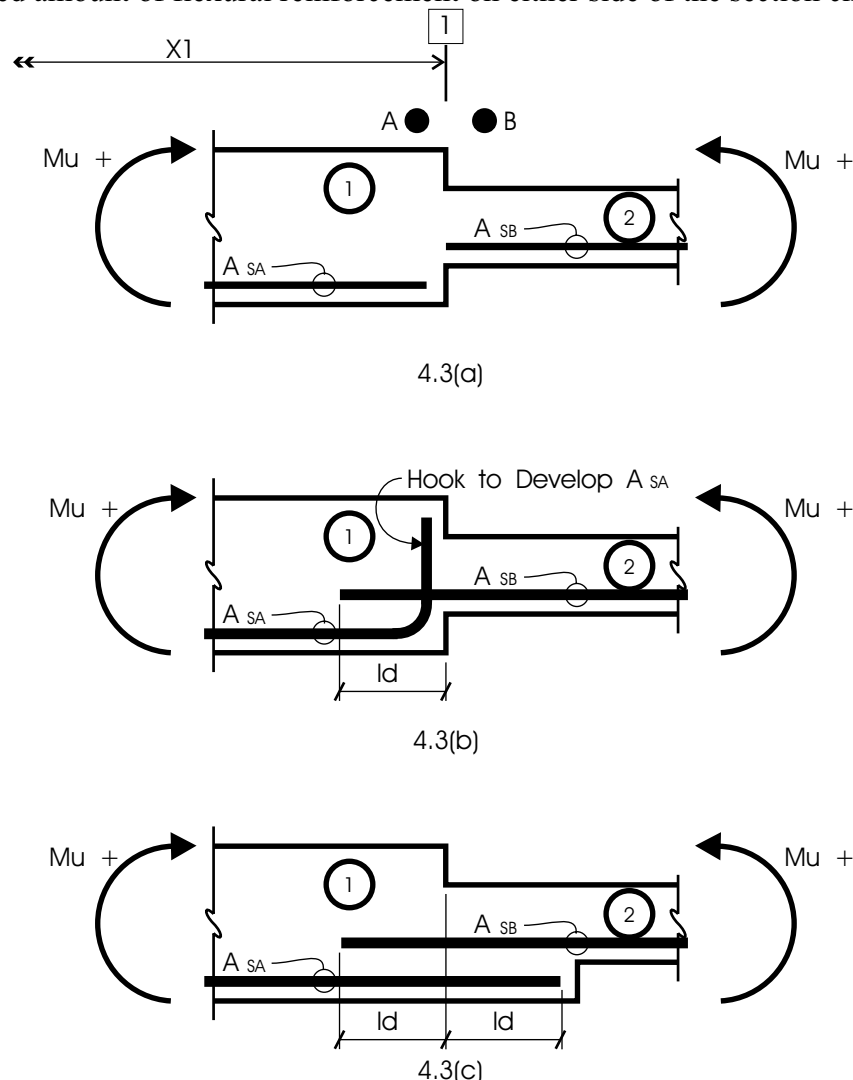

Figure 4.3 - Development of Reinforcement at Section Change

does not directly address the development of this reinforcement. For example, in Figure 4.3(a), in an area of positive moment, a change in cross section from Section 1 to Section 2 occurs at point 1. The program will investigate each side of the point 1, point *A* on the left side and point *B* on the right side, and determine the amount of flexural reinforcement A_{sa} and A_{sb} required at each point. However bars A_{sa} and A_{sb} must both be developed beyond point 1. Bars A_{sb} can be easily developed by just extending them to the left into Section 1. However the user must provide some means of developing bars A_{sa} , which run out of beam at Point 1. Suggested solutions to the development of these bars A_{sa} are shown in Figures 4.3(b) and 4.3(c). It is emphasized that, although **PTData+** calculates the required amount of flexural reinforcing at a specified number of points in the frame, the user is responsible for the development of this reinforcement, not only at points of section change, but throughout the frame. In general this is a straightforward task involving the extension of bars beyond the points where they are no longer required (a point determined by the program), however some areas require special consideration such as the one discussed above.

Chapter Five

Tendon Profiles

PTData+ supports a library of 12 tendon profiles, 7 for spans and 5 for cantilevers. Any one of the available tendon profiles may be used in each span or cantilever. The library of tendon profiles is shown in Figure 5.1. The tendon profile numbers shown in Figure 5.1 are used to input the desired tendon profile. Figure 5.1 also shows the types of equivalent loads applied to the concrete by each tendon profile due to its curvature. The magnitude of these loads is discussed in Chapter 6. The user selects a tendon profile type for each span of the frame, and supplies the pertinent data required to define each type. A literal value shown in a tendon profile type in Figure 5.1 indicates a value which must be specified by the user. The tendon types are discussed below (Types 1 through 7 are for spans, Types 8 through 12 are for cantilevers. The discussion is for spans, the extension to cantilevers should be obvious):

5.1 - Types 1 and 8 (Centerline Parabola)

This is a simple parabola (no reversed curvature) with its high points at the two support centerlines. It produces a uniform upward load on the concrete between high points equilibrated by downward loads applied directly into the supports, which are not shown. The downward loads do not produce bending in the concrete-only freebody, however they do affect the external reactions produced by the equivalent loads and therefore the “secondary” moments in the concrete/tendon freebody (see Chapter 2). No additional parameters are required to define this tendon profile other than its type number.

5.2 - Types 2 and 9 (Face to Face Parabola)

This is a simple parabola with its high points inside the support centerlines. The high points are normally located at the faces of the supports. The tendon is straight between the high point and the support centerline. This profile produces a uniform upward load between high points and downward point loads at the two high points. The dimensions c_l and c_r between the left and right support centerlines and the respective high points are required to define this profile.

5.3 - Types 3 and 12 (Compound Parabola)

The Type 3 profile consists of four parabolas, two concave downward at the supports and two concave upward between them. The user specifies the two points of contraflexure A and B (measured from the left and right support centerlines respectively) and the tendon lowpoint location C (always measured from the left support

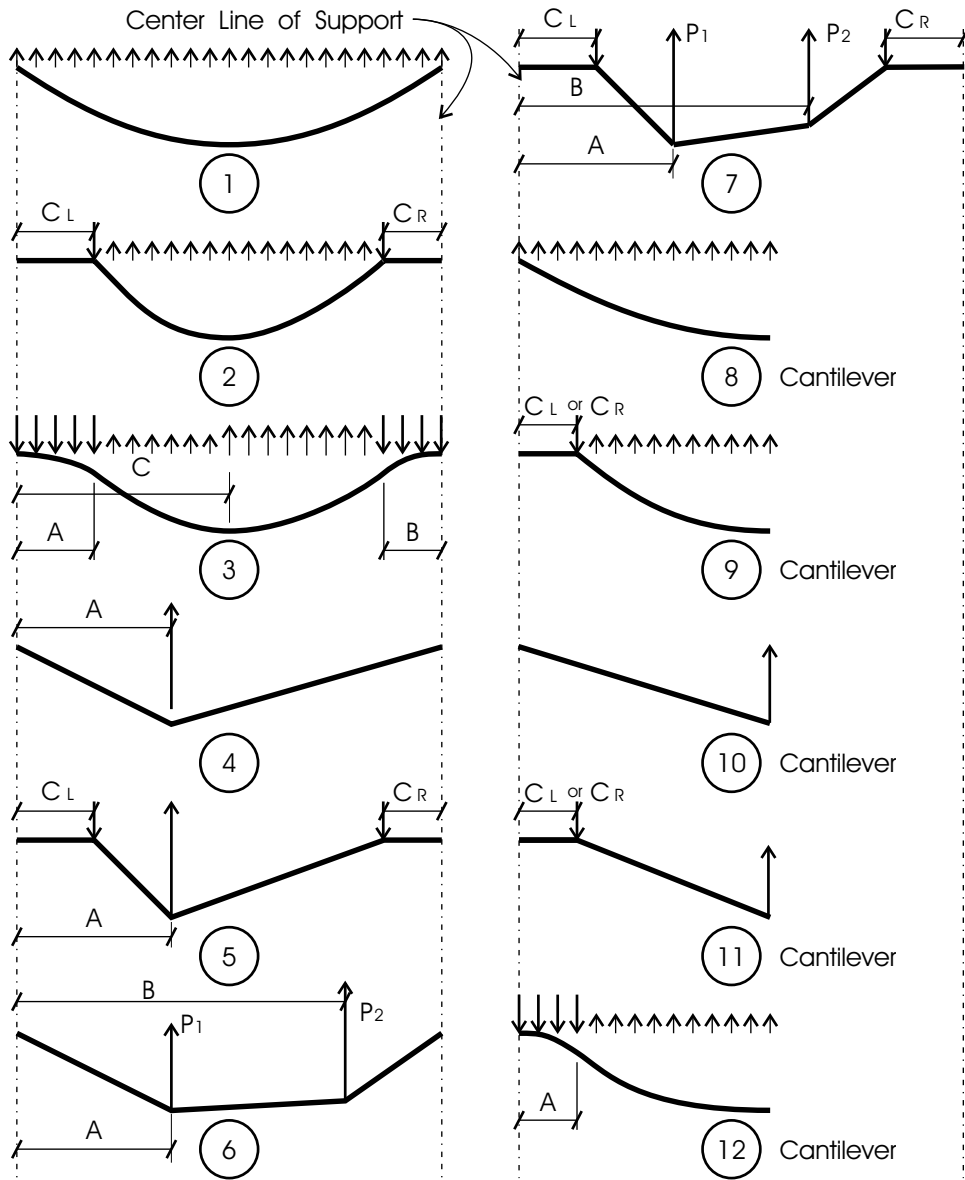

Figure 5.1 - Tendon Profile Types

centerline). The program determines the profile such that the slopes of the adjacent parabolas are the same at the points of contraflexure. This tendon profile produces four segments of uniform loads, one for each parabola. The center segments apply upward loads, the other two downward loads. A and B can be unequal or one of them can be zero if desired. C must be greater than B and less than $L-B$.

The Type 12 profile (cantilever compound parabola) consists of two parabolas, one concave downward at the support and one concave upward in the remainder of the cantilever. The user specifies the single point of contraflexure A , measured from the cantilever support for either left or right cantilevers. This tendon profile produces two segments of uniform loads, one downward near the support, the other upward.

5.4 - Types 4 and 10 (Single Point Centerline Harp)

A straight-line harped tendon profile with high points at the support centerlines and a single “bend” in between. This profile produces one upward point load on the concrete at the bend point. As in the Type 1 profile, the downward point loads at the high point are applied directly into the supports and are not shown. The user specifies the location of the bend point A , measured from the left support centerline.

5.5 - Types 5 and 11 (Single Point Face to Face Harp)

A straight-line harped tendon profile with high points inside the support centerlines at points c_l and c_r , which are specified by the user and measured from the left and right support centerlines respectively. This profile produces one upward point load at the bend point and a downward point load at each of the two high points.

5.6 - Type 6 (Double Point Centerline Harp)

A straight-line harped tendon profile with high points at the support centerlines. This profile produces two upward point loads at the two bend points A and B , both measured from the left support centerline. P_1 and P_2 represent the relative values of the left and right equivalent loads at A and B respectively. They are used to establish the “optimum” tendon profile in the computer-generated design performed by **PTData+** (see Chapter 9). For example, the user might input for P_1 and P_2 the values of the applied concentrated dead loads at those two points. In the computer-generated design, then, **PTData+** will establish a tendon profile for that span in which the ratio of the equivalent load at A to that at B will always be P_1/P_2 . This ratio of P_1/P_2 is maintained only in the computer-generated design - the final tendon profile can be modified in any way by the user.

5.7 - Type 7 (Double Point Face to Face Harp)

A straight-line harped tendon profile with high points inside the support centerlines at points c_l and c_r , which are specified by the user and measured from the left and right support centerlines respectively. This profile produces two upward point loads at the two bend points A and B , both measured from the left support centerline, and a downward point load at each of the two high points. P_1 and P_2 are as discussed above in Section 5.6.

Chapter Six

Equivalent Loads

To determine the elastic moments and shears (M_{bal} and V_{bal}) in the frame caused by prestressing, **PTData+** uses the equivalent load method of analysis. In this method the tendons are replaced with all of the loads they exert on the concrete. The resulting freebody (consisting of the concrete beams and columns with tendon loads and no tendons) is then analyzed for moments and shears produced by the equivalent loads. These equivalent, or “balanced” load moments (M_{bal}) are used to calculate flexural concrete stresses and secondary moments in the frame (see Chapter 2).

Equivalent tendon loads are produced when one or more of the following conditions are present:

1. Tendon curvature.
2. A discontinuity in the location of the concrete *CGC* or *CGS at a point* in the frame.
3. A discontinuity in the prestress force *at a point* in the frame, such as that which occurs at tendon anchorage points.
4. A change in prestress force *between two points* along a tendon, such as that produced by tendon friction with the adjacent concrete.

Items 1 through 3 above apply in either Constant Force or Variable Force methods. Item 4 is a special case of Item 3 and applies only in the Variable Force Method.

6.1 - Equivalent Loads in the Constant Prestress Force Method

When the tendon force is constant along the full length of the tendon, equivalent loads are generated by conditions 1 through 3 above. Since the angles the tendon profile makes with the horizontal are assumed to be small, all curvature loads are assumed to be vertical. For the same reason, equivalent loads generated by a discontinuity in prestress force (condition #3 above) are assumed to be horizontal. Sections 6.1(a) through (d) describe how *all* of the equivalent loads (for both continuous and added tendons) are calculated in the Constant Prestress Force Method.

6.1(a) - Curvature Loads for Each Tendon Type

Figure 6.1 shows graphically all of the equivalent curvature-generated loads for each of the 12 available tendon profiles in a span or cantilever. For the cantilever profiles, a right cantilever is shown. Left cantilevers are identical (opposite hand) with the subscript L replaced with R. Following are the equations for all of the curvature loads shown in Figure 6.1. In each profile the tendon force is F , and all equivalent loads are shown positive.

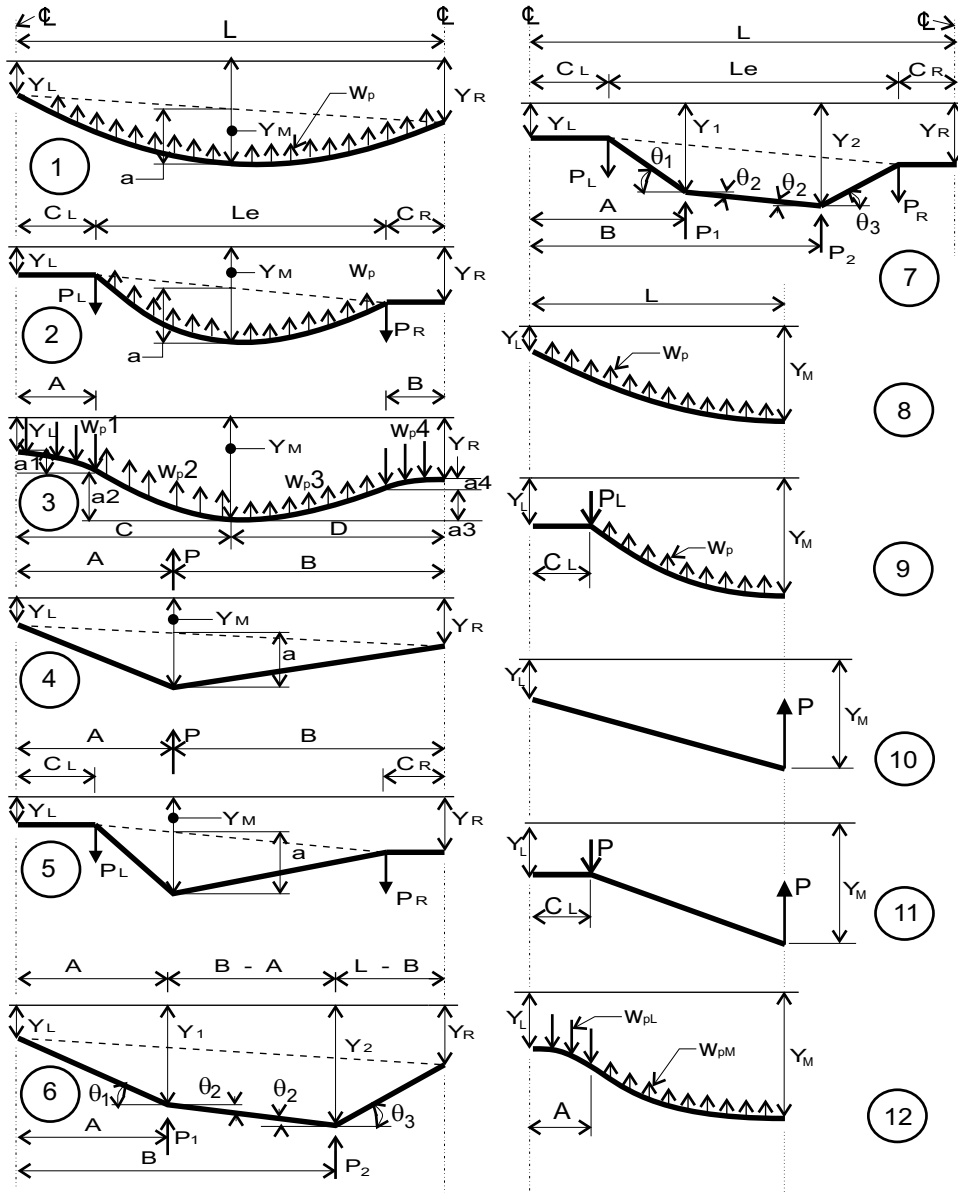

Figure 6.1 - Tendon Curvature Loads

Type 1 profile:

$$a = Y_M - \left(\frac{Y_L + Y_R}{2} \right)$$

$$w_p = \frac{8Fa}{L^2}$$

Type 2 profile:

$$a = Y_M - \left(\frac{Y_L + Y_R}{2} \right)$$

$$w_p = \frac{8Fa}{L_e^2}$$

$$P_L = \frac{w_p L_e}{2} + \frac{(Y_R - Y_L)F}{L_e}$$

$$P_R = \frac{w_p L_e}{2} - \frac{(Y_R - Y_L)F}{L_e}$$

Type 3 profile:

- The “sub-sags” for the four parabolic tendon segments:

$$a_1 = \frac{A}{C}(Y_M - Y_L)$$

$$a_2 = Y_M - Y_L - a_1$$

$$a_3 = Y_M - Y_R - a_4$$

$$a_4 = \frac{B}{D}(Y_M - Y_R)$$

- The equivalent loads for each segment:

$$w_{\rho 1} = \frac{2Fa_1}{A^2}$$

$$w_{\rho 2} = \frac{2Fa_2}{(C-A)^2}$$

$$w_{\rho 3} = \frac{2Fa_3}{(D-B)^2}$$

$$w_{\rho 4} = \frac{2Fa_4}{B^2}$$

Type 4 profile:

$$a = Y_M + \left(Y_L + \frac{A}{L} (Y_R - Y_L) \right)$$

$$P = \frac{FaL}{AB}$$

Type 5 profile:

$$a = Y_M - \left(Y_L + \frac{A - c_L}{L_e} (Y_R - Y_L) \right)$$

$$P = \frac{FaL_e}{(A - c_L)(B - c_R)}$$

$$P_L = \frac{P(B - c_R)}{L_e} + \frac{F(Y_R - Y_L)}{L_e}$$

$$P_R = \frac{P(A - c_L)}{L_e} - \frac{F(Y_R - Y_L)}{L_e}$$

Type 6 profile:

$$P_1 = F \left[\frac{Y_1 - Y_2}{A} - \frac{Y_2 - Y_1}{B - A} \right]$$

$$P_2 = F \left[\frac{Y_2 - Y_R}{L - B} + \frac{Y_2 - Y_1}{B - A} \right]$$

Type 7 profile:

$$P_1 = F \left[\frac{Y_1 - Y_L}{A - c_L} - \frac{Y_2 - Y_1}{B - A} \right]$$

$$P_2 = F \left[\frac{Y_2 - Y_R}{L_e - B} + \frac{Y_2 - Y_1}{B - A} \right]$$

$$P_L = \frac{P_1(A - c_L - L_e)}{L_e} + \frac{P_2(B - c_L - L_e)}{L_e} + \frac{F(Y_L - Y_R)}{L_e}$$

$$P_R = \frac{P_1(c_L - A)}{L_e} + \frac{P_2(c_L - B)}{L_e} - \frac{F(Y_L - Y_R)}{L_e}$$

Type 8 profile:

$$w_p = \frac{2F(Y_M - Y_L)}{L^2}$$

Type 9 profile:

$$w_p = \frac{2F(Y_m - Y_L)}{L_e^2}$$

$$P_L = w_p(L - c_L)$$

Type 10 profile:

$$P = \frac{F(Y_M - Y_L)}{L}$$

Type 11 profile:

$$P = \frac{F(Y_M - Y_L)}{L - c_L}$$

$$P_L = P$$

Type 12 profile:

$$a_L = \frac{(Y_M - Y_L)A}{L}$$

$$a_M = \frac{(Y_M - Y_L)(L - A)}{L}$$

$$w_{pL} = \frac{2Fa_L}{A^2}$$

$$w_{pM} = \frac{2Fa_M}{(L - A)^2}$$

6.1(b) - CGC and CGS Discontinuities

Figure 6.2 shows the equivalent tendon load, a concentrated moment, produced at a point where the concrete *CGC* changes. **PTData+** supports different tendon *CGS* values on either side of a joint, to model the effect of an offset beam. Figure 6.3 shows the equivalent tendon load, also a concentrated moment, produced at such a joint in the frame where the concrete *CGC* changes AND the tendon *CGS* changes.

6.1(c) - Tendon Force Discontinuities

Figure 6.4 shows the equivalent tendon loads produced at discontinuities in tendon forces, i.e., at external tendon anchorage points. The equivalent loads produced by “dead-end” or interior anchorages of added tendons are addressed in item 6.1(d). The remaining exterior anchorage points, which occur at both ends of the frame, are addressed in this section. At such a point the tendon applies a force *F* to the concrete. Using small angle theory, the horizontal component of this force is assumed to be equal to the force itself, thus these forces *F* are all applied horizontally. They produce the axial compression in the frame beams. If the force *F* is applied at a point other

than the concrete *CGC* a concentrated moment Fe is also generated at this point as shown in Figure 6.4, where e is the distance between the *CGS* and the *CGC* at the point of application of F .

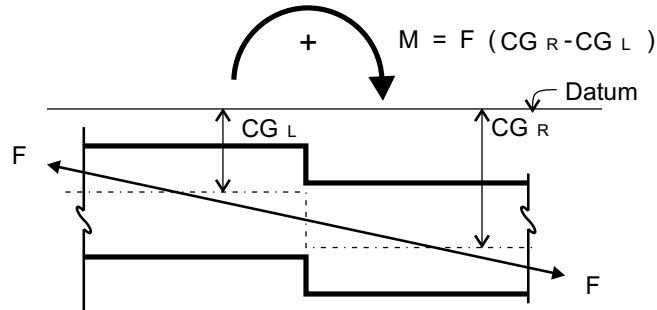

Figure 6.2 - Induced Moment at Section Discontinuity

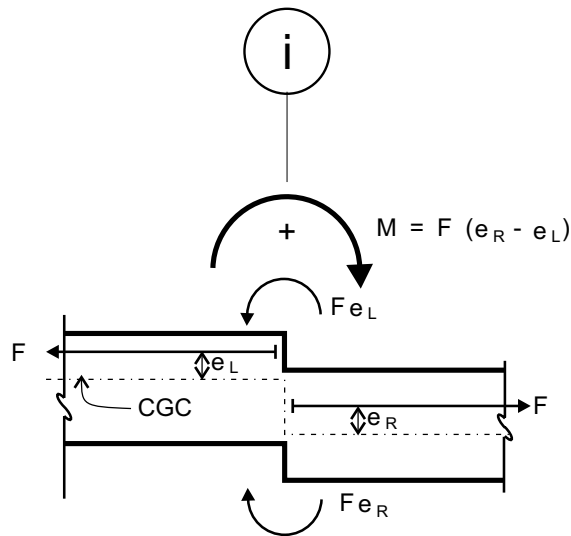

Figure 6.3 - Induced Moment at CGC & CGS Discontinuity

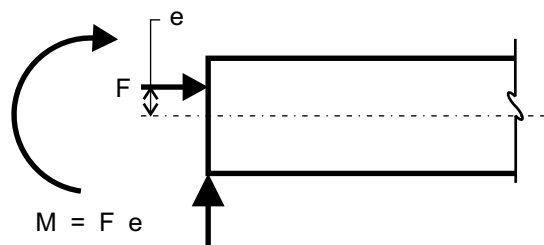

Figure 6.4 - Induced Moment at Beam End

6.1(d) - Equivalent Loads for Added Tendons

An added tendon is a tendon which is present in only some of the spans of the frame, i.e., it is not continuous from end to end of the frame. The “dead-end”, or fixed anchor of an added tendon is located in the span adjacent to the last span in which the added tendon is needed. **PTData+** assumes that all added tendons end at the first sixth point of this span (third point for cantilevers), and that the added tendon follows the same profile as the continuous tendons in that span. The portion of the added tendon in the span containing its deadend anchor is called the “tail” of the added tendon. Added tendon tails produce a special set of equivalent loads. Figures 6.5 and 6.6 show the equivalent tendon loads produced by added tendon tails in the constant force method for all tendon profiles. Following are the equations for equivalent loads produced by added tendon tails, using F for the tendon force in each profile:

Type 1 Profile:

$$a = Y_M - \left(\frac{Y_L + Y_R}{2} \right)$$

$$w_p = \frac{8Fa}{L^2}$$

$$P_{bL} = \frac{w_p L}{3} + \frac{F(Y_R - Y_L)}{L}$$

$$P_{bR} = \frac{w_p L}{3} - \frac{F(Y_R - Y_L)}{L}$$

$$M_L = Fe_L$$

$$M_R = Fe_R$$

Type 2 Profile:

$$a = Y_M - \left(\frac{Y_L + Y_R}{2} \right)$$

$$w_p = \frac{8Fa}{L_e^2}$$

$$P_L = \frac{w_p L_e}{2} + \frac{(Y_R - Y_L)F}{L_e}$$

$$P_R = \frac{w_p L_e}{2} - \frac{(Y_R - Y_L)F}{L_e}$$

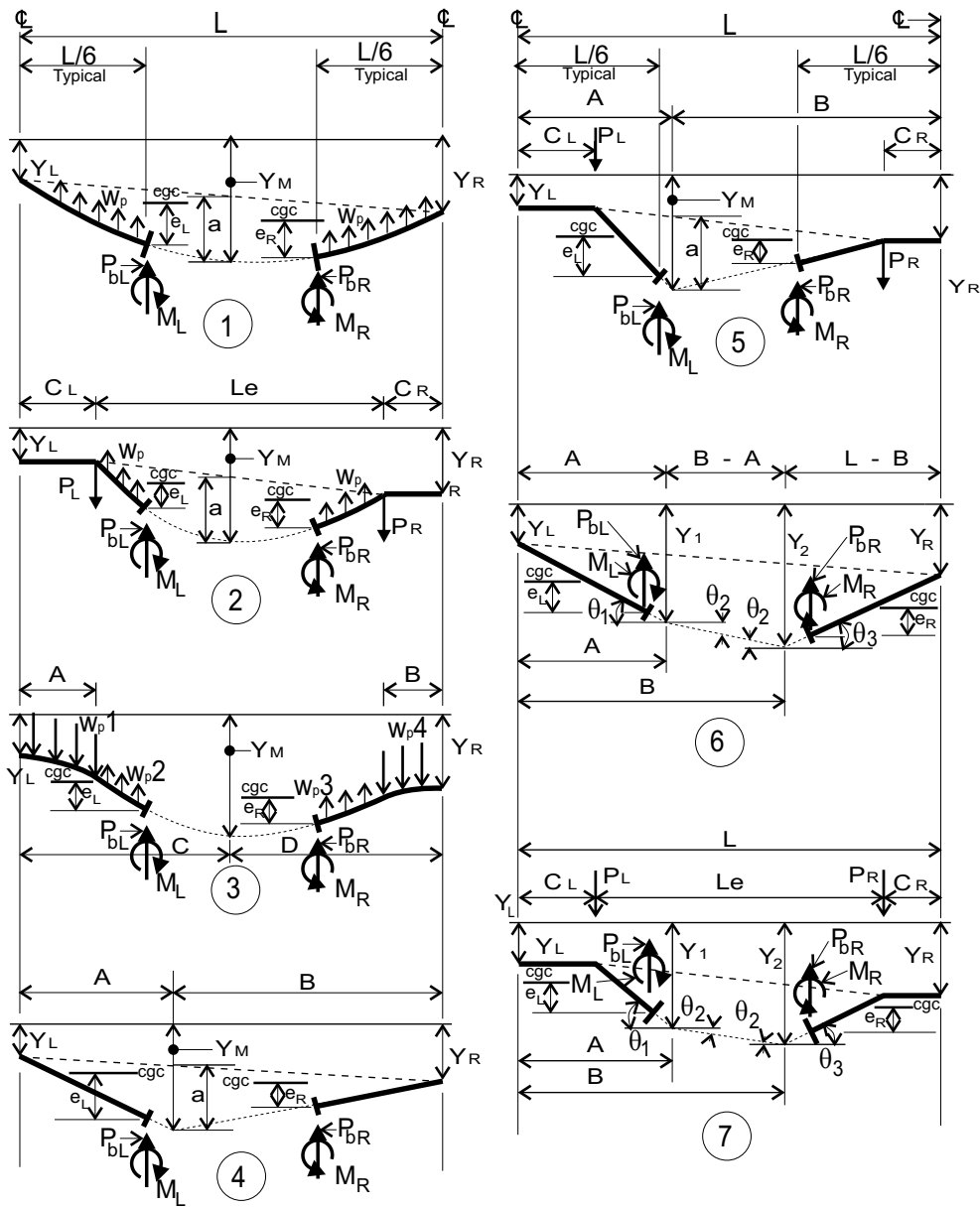

Figure 6.5 - Added Tendon Curvature Loads - Spans

$$P_{bL} = P_L - w_p \left(\frac{L}{6} - c_L \right)$$

$$P_{bR} = P_R - w_p \left(\frac{L}{6} - c_R \right)$$

$$M_L = Fe_L$$

$$M_R = Fe_R$$

Type 3 Profile:

- The “sub-sags” for the four parabolic tendon segments:

$$a_1 = \frac{A}{C} (Y_M - Y_L)$$

$$a_2 = Y_M - Y_L - a_1$$

$$a_3 = Y_M - Y_R - a_4$$

$$a_4 = \frac{B}{D} (Y_M - Y_R)$$

- The equivalent loads for each tail:

$$w_{p1} = \frac{2Fa_1}{A^2}$$

$$w_{p2} = \frac{2Fa_2}{(C - A)^2}$$

$$w_{p3} = \frac{2Fa_3}{(D - B)^2}$$

$$w_{p4} = \frac{2Fa_4}{B^2}$$

$$P_{bL} = w_{p1}A - w_{p2}\left(\frac{L}{6} - A\right)$$

$$\left(\frac{L}{6} - A\right) \geq 0$$

$$P_{bR} = w_{p4}B - w_{p3}\left(\frac{L}{6} - B\right)$$

$$\left(\frac{L}{6} - B\right) \geq 0$$

$$M_L = Fe_L$$

$$M_R = Fe_R$$

Type 4 Profile:

$$P_{bL} = \frac{F(Y_M - Y_L)}{A}$$

$$P_{bR} = \frac{F(Y_M - Y_R)}{B}$$

$$M_L = Fe_L$$

$$M_R = Fe_R$$

Type 5 Profile:

$$P_{bL} = P_L = \frac{F(Y_M - Y_L)}{(A - c_L)}$$

$$P_{bR} = P_R = \frac{F(Y_M - Y_R)}{(B - c_R)}$$

$$M_L = Fe_L$$

$$M_R = Fe_R$$

Type 6 Profile:

$$P_{bL} = P_L = \frac{F(Y_1 - Y_L)}{A}$$

$$P_{bR} = P_R = \frac{F(Y_2 - Y_R)}{L - B}$$

$$M_L = Fe_L$$

$$M_R = Fe_R$$

Type 7 Profile:

$$P_{bL} = P_L = \frac{F(Y_1 - Y_L)}{A - c_L}$$

$$P_{bR} = P_R = \frac{F(Y_2 - Y_R)}{L - B - c_R}$$

$$M_L = Fe_L$$

$$M_R = Fe_R$$

Type 8 Profile:

$$w_p = \frac{2F(Y_M - Y_L)}{L^2}$$

$$P_b = \frac{2w_p L}{3}$$

$$M = Fe$$

Type 9 Profile:

$$w_p = \frac{2F(Y_m - Y_L)}{L_e^2}$$

$$P_b = \frac{2w_p L}{3}$$

$$M = Fe$$

Type 10 Profile:

$$P_b = \frac{F(Y_M - Y_L)}{L}$$

$$M = Fe$$

Type 11 Profile:

$$P_b = P = \frac{F(Y_M - Y_L)}{L - c_L}$$

$$M = Fe$$

Type 12 Profile:

$$a_L = \frac{(Y_M - Y_L)A}{L}$$

$$a_M = \frac{(Y_M - Y_L)(L - A)}{L}$$

$$w_{pL} = \frac{2Fa_L}{A^2}$$

$$w_{pM} = \frac{2Fa_M}{(L - A)^2}$$

$$P_b = w_{pL}A - w_{pM}\left(\frac{L}{3} - A\right)$$

$$M = Fe$$

Together Figures 6.1 through 6.6 include all of the equivalent tendon loads used by **PTData+** in the constant prestress force method.

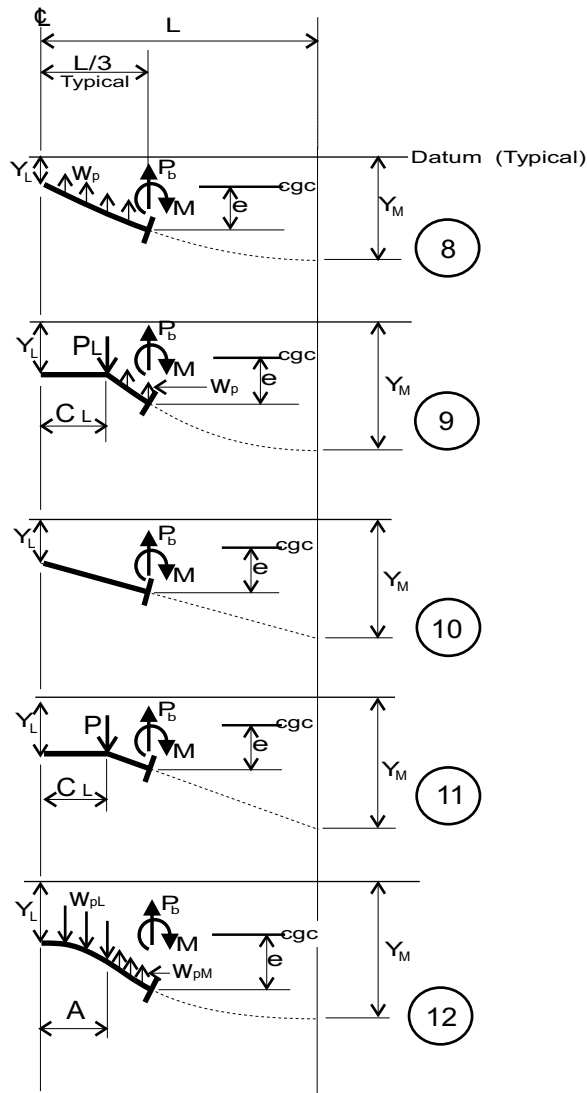

Figure 6.6 - Added Tendon Curvature Loads - Cantilevers

6.2 - Equivalent Loads in the Variable Prestress Force Method

In the variable force method **PTData+** divides each span into a series of segments and determines the equivalent tendon loads for each segment. One such tendon segment is shown isolated as a freebody in Figure 6.7. In this elemental segment, the tendon is curved (the tendon slope is different at each end of the segment), and the force is variable (the tendon force is different at each end of the segment). The concrete exerts a force on the tendon segment to equilibrate it and this force is shown in vertical and horizontal components (R_V and R_H) in Figure 6.7. Angles ϕ_L and ϕ_R are assumed to be small such that the horizontal components of the tendon force F_L and F_R can be taken equal to F_L and F_R respectively.

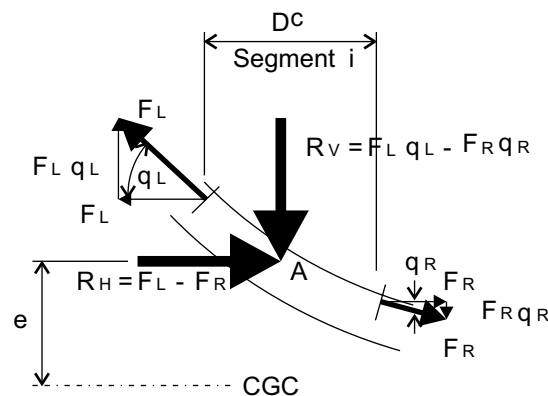

Figure 6.7 - Forces Acting on Tendon Segment "i"

The vertical component R_v of the force exerted on the concrete by the tendon segment can be broken down into two parts as shown in Figure 6.8. The first part, R_{vc} , is produced by tendon curvature and is equal to the average force in the segment multiplied by the difference in the tendon slope at each end of the segment. The second part, R_{vf} , is produced by tendon friction and is equal to the average slope of the tendon segment multiplied by the difference in tendon force at each end of the segment. The effects of tendon friction on the segment (R_{hf} and R_{vf}) can thus be isolated from the effects of tendon curvature (R_{vc}). It should be noted that the forces R_{hf} , R_{vf} , and R_{vc} are shown in Figure 6.7 acting on the tendon segment. Figure 6.8 shows the equal and opposite set of forces acting on the concrete at each tendon segment.

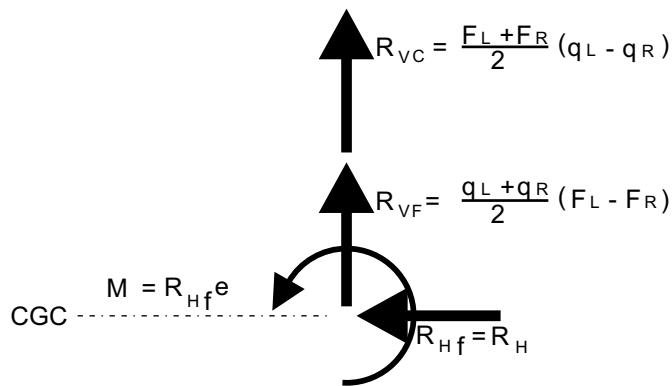

Figure 6.8 - Equivalent Concrete Loads at Segment “i”

To model the effects of the tendon loads with variable prestress force, each span is divided into ten segments and the tendon loads R_{vc} , R_{vf} , and R_{vc} are calculated for each segment, as shown in Figure 6.8. The horizontal friction component R_{hf} produces the variable tendon force and an applied concentrated moment $R_{hf}e$, assumed to act at the center of the segment, where e is the distance between the tendon CGS and the center of gravity of the concrete cross-section (the CGC). The vertical component of the tendon friction force R_{vf} is assumed to act as a point load at the center of the segment. The curvature load R_{vc} is uniformly distributed over the segment if the tendon profile is parabolic. Sharp bends in the tendon profile produce point loads on the concrete at the bend points. A change in member cross-section produces a concentrated moment at that point as discussed in 6.1(b) and exterior anchorage points are handled as in 6.1(c).

Chapter Seven

Flexural and Torsional Stiffnesses

The flexural stiffness of a frame beam or column is the moment required to rotate its end through an angular change of 1 radian. It is an important parameter used to determine the frame moments and all other values related to the moments. In **PTData+**, where the beams and columns are generally non-prismatic, the column analogy method is used to determine the beam and column stiffnesses. A description of the column analogy method can be found in most structural analysis textbooks.

The assumptions involved in the calculation of stiffnesses for frame beams is different for the rigid frame method and the equivalent frame method. In the rigid frame method the frame beams and columns are rigidly connected to each other at the joint (the end rotations of all beams and columns at a particular joint are equal) and the flexural stiffness calculations involve only the physical beams and columns themselves. In the equivalent frame method, where the “beam” is usually much wider than the column, the beam is rigidly connected to the column only over a small percentage of the beam width. Elsewhere the beam is assumed to be connected to a “torsional member”, which acts like a spring connected to the column. In an equivalent frame the end rotations of beams and columns framing into a particular joint are not equal. Thus the calculation of stiffness for an equivalent frame involves not only the calculation of flexural stiffness for the frame beams and columns, but also the stiffness of the torsional member.

The method used for calculating the stiffnesses of each member is discussed below:

7.1 - Columns (Rigid or Equivalent Frame)

Each frame column (one above and one below each joint) is described by entering one value for length (L_c), one set of either rectangular or round cross-sectional dimensions, and the far-end fixity condition (fixed or pinned). One input value of modulus of elasticity E_c applies to all frame columns. The input column length L_c extends from the point of fixity or the pin at the far end to the center of the total beam depth h of the frame beam. If the beam depth h varies on either side of the column the side with the larger h is used. The moment of inertia of the column is assumed to be infinite within the depth of the beam (the first $h/2$ of the column length) and I_g elsewhere, where I_g is the gross moment of inertia of the input cross section geometry. This is shown in Figure 7.1. Using the column analogy method an expression for the flexural stiffness of the frame columns can be derived. For columns fixed at the far end:

$$K_c = \frac{2E_c I_g}{2L_c - h} \left(1 + \frac{3(2L_c + h)^2}{(2L_c - h)^2} \right) \quad \text{(Eqn. 7-1)}$$

For columns pinned at the far end:

$$K_c = \frac{24E_c I_g L_c^2}{(2L_c - h)^3} \quad \text{(Eqn. 7-2)}$$

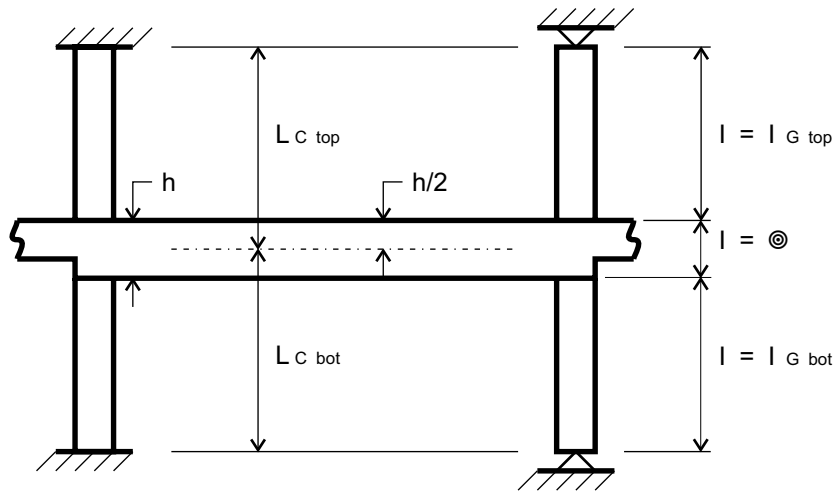

Figure 7.1 - Column Properties

7.1(a) - Modeling of Top and Bottom Columns

In many post-tensioned concrete buildings the top column at a joint is not structurally complete at the time the tendons are stressed. In order for the top column to contribute stiffness, to “take” moment, not only must the top column be intact, but so must be the beam above, and in many buildings this does not occur until well after the tendons are stressed and most of the dead load is on the frame. **PTData+** contains an option for calculating frame moments which considers only the bottom column present under dead load and equivalent loads, and both top and bottom columns present for live loads. This permits a rational method to model the actual construction condition described above. Alternatively, top and bottom columns may both be considered present under all loading conditions if desired. This column modeling option applies in both the rigid and equivalent frame method.

7.2 - Rigid Frame Beams

The flexural stiffness of each rigid frame beam is a function of the moment of inertia of each different beam segment within the span, and the input value of the beam modulus of elasticity (E_b) which applies to all frame beams. The moment of inertia is based upon the **gross concrete section** specified for each beam segment. For rigid frame analysis, **PTData+** assumes the moment of inertia of the beam is infinite in the area common to the beam and column. These criteria for rigid frame beams are shown in Figure 7.2.

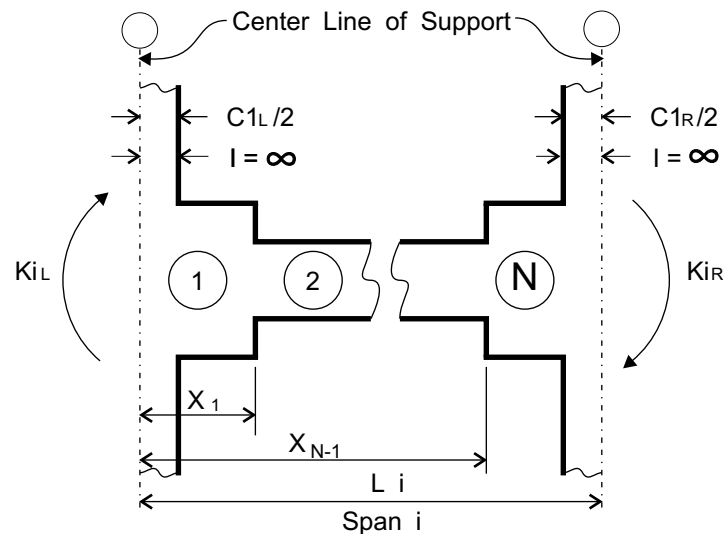

7.2 - Flexural Stiffness of Rigid Frame Beams

7.3 - Equivalent Frame Geometry and Definitions

The equivalent frame method is an analytical tool which models a two-way framing system as a series of one-way beam-column frames in each of two orthogonal directions. The horizontal framing systems can be pure flat plates (two-way solid thickness slabs), two-way slabs with drop panels, beams in one or both directions, or any combination of the above. In the equivalent frame method the horizontal members (collectively called the “beams”), are assumed to be connected to an “equivalent” column, which consists of the real column and a “torsional member” which acts like a spring to reduce the effective stiffness of the real column and accurately model the relative stiffnesses of the frame members.

The fundamental definitions and dimensions for the equivalent frame method are shown in Figure 7.3, a plan of Span i of an equivalent frame centered at grid line 3. Dimensions with a subscript of “1” are parallel to the equivalent frame (in the same plane as the equivalent frame), those with a subscript of “2” are perpendicular to the plane of the equivalent frame. Columns at $i/3$ and $(i+1)/3$ have dimensions c_1 and c_2 ,

parallel and perpendicular to the beam span respectively. The L_2 dimensions at these two columns are different on either side. In **PTData+** planes perpendicular to the primary frame are always viewed *looking to the left*. Thus at column $i/3$ the L_2 dimension between columns $i/3$ and $i/4$ is denoted L_{2l} and the L_2 dimension between columns $i/3$ and $i/2$ is denoted L_{2r} . Note how the slab edge “jog” in span i and the column arrangement at $i/1$ and $i/2$ affects the width of the equivalent frame beams. The torsional member to the north of column $i/3$ connects to the closest column on grid line i , therefore the L_{2r} dimension at $i/3$ is that between $i/3$ and $i/2$. Column $i/1$, and the dimension L_{2ra} , define the width, or tributary, of the equivalent frame beam in Span $i-1$. The widths of the equivalent frame beams are half the distance to the adjacent left and right frames, or the “tributary” at each point along the beam. In Figure 7.3 the equivalent frame beam width for span i is $(L_{2l}+L_{2r})/2$.

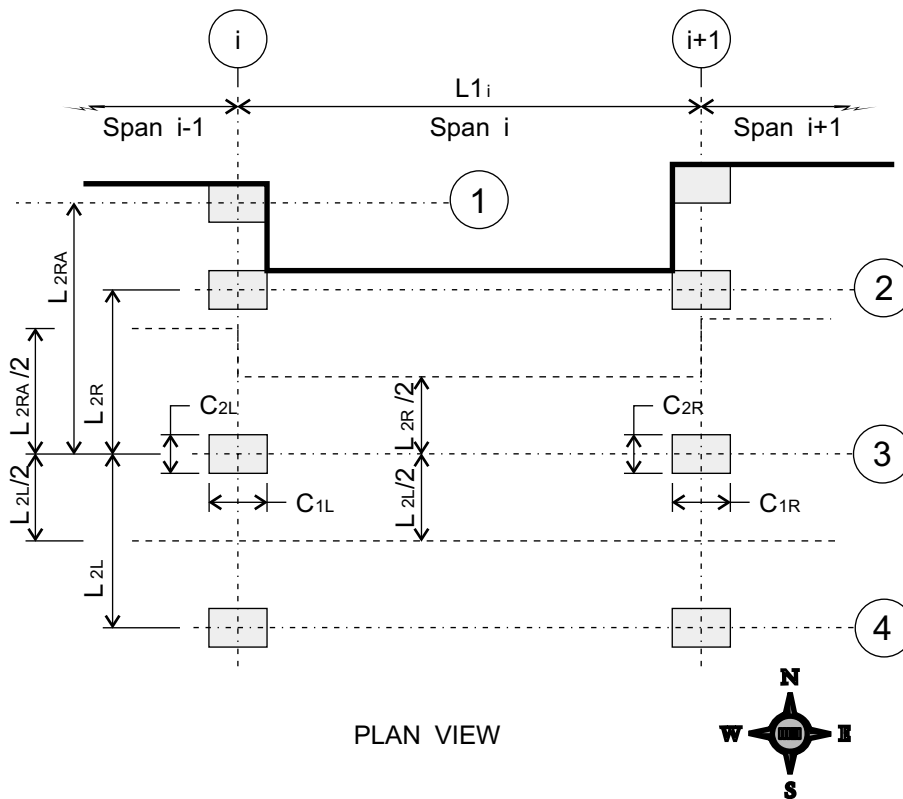

Figure 7.3 - Basic Equivalent Frame Dimensions

7.4 - Equivalent Frame Beams

The flexural stiffness of an equivalent frame beam is identical to that of a rigid frame beam (Section 7.2) with one exception. The moment of inertia between the centerline of the support and the face of the support, assumed infinite in the rigid frame method, is assumed to be $(1-c_2/L_2)^2$ times the moment of inertia of the beam segment adja-

cent to the support. This accounts for the fact that the equivalent frame beam is not physically connected to the column for its full width. These criteria for equivalent frame beams are shown in Figure 7.4.

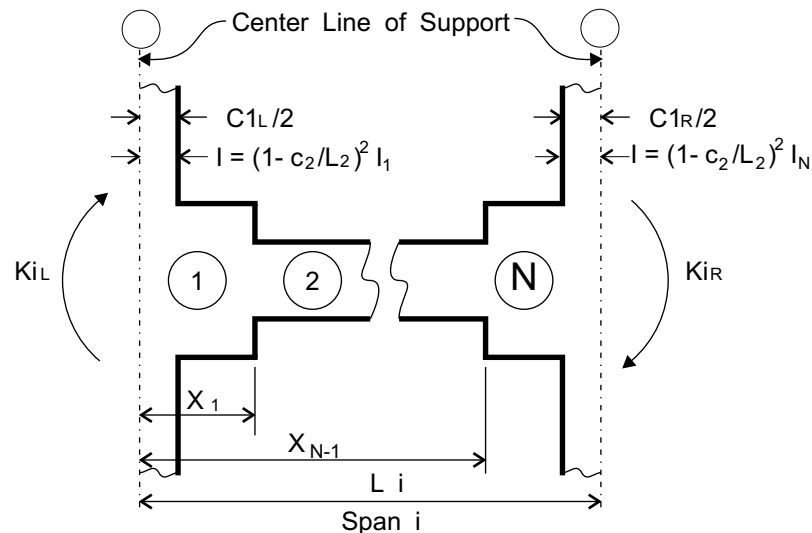

Figure 7.4 - Flexural Stiffness of Equivalent Frame Beams

7.5 - Equivalent Frame Torsional Members

PTData+ supports two types of torsional members at each frame joint in accordance with Chapter 13 of the ACI Standard Building Code. Either one of the two types may occur at each of the frame joints. One type is contained entirely within the geometry of the primary equivalent frame beams specified in either span at each joint. This type of torsional member will be called the “primary” torsional member. The other type of torsional member will be called the “transverse beam”. The transverse beam torsional member exists when a beam is specified at a frame joint, perpendicular to the plane of the equivalent frame, with beam geometry extending outside of the primary equivalent frame beam dimensions.

All torsional members are perpendicular to the plane of the equivalent frame and connect to columns in other frames adjacent to the primary equivalent frame. Torsional members may be different on either side (left or right) of each frame joint, or they may be absent on one side as in an edge frame.

7.5(a) - The “Primary” Torsional Member

The cross section of the primary torsional member at joint i is a rectangle whose width is the c_1 dimension of the column at joint i . The depth of the rectangle is the dimension between the top of the highest adjacent beam cross-section at joint i and the bottom of the lowest adjacent beam cross section at joint i .

To demonstrate the determination of primary torsional member dimensions, Figure 7.5 shows a plan view at column $i/2$ where the beam sections i_L and i_r at the left and right sides of joint i are selected to model a double drop cap at the column. Beam cross sections i_L and i_r are shown in Figure 7.6, both oriented vertically with respect to a constant datum line. Note that the tops and the bottoms of the beam sections are different on each side of joint i . The torsional member to the right of column $i/2$ has three different cross sections located in plan in Figure 7.5 and shown in cross-section in Figure 7.7.

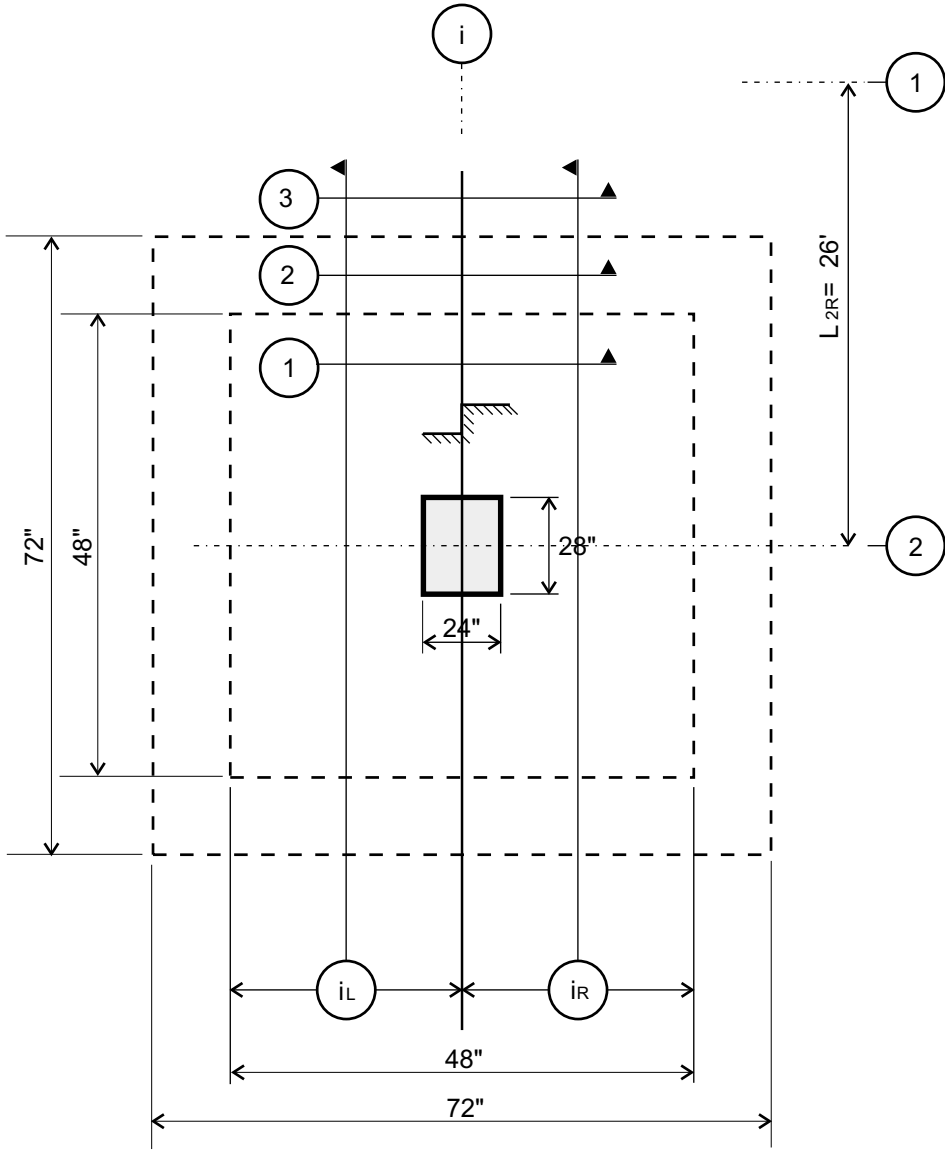

Figure 7.5 - Primary Torsional Member Example

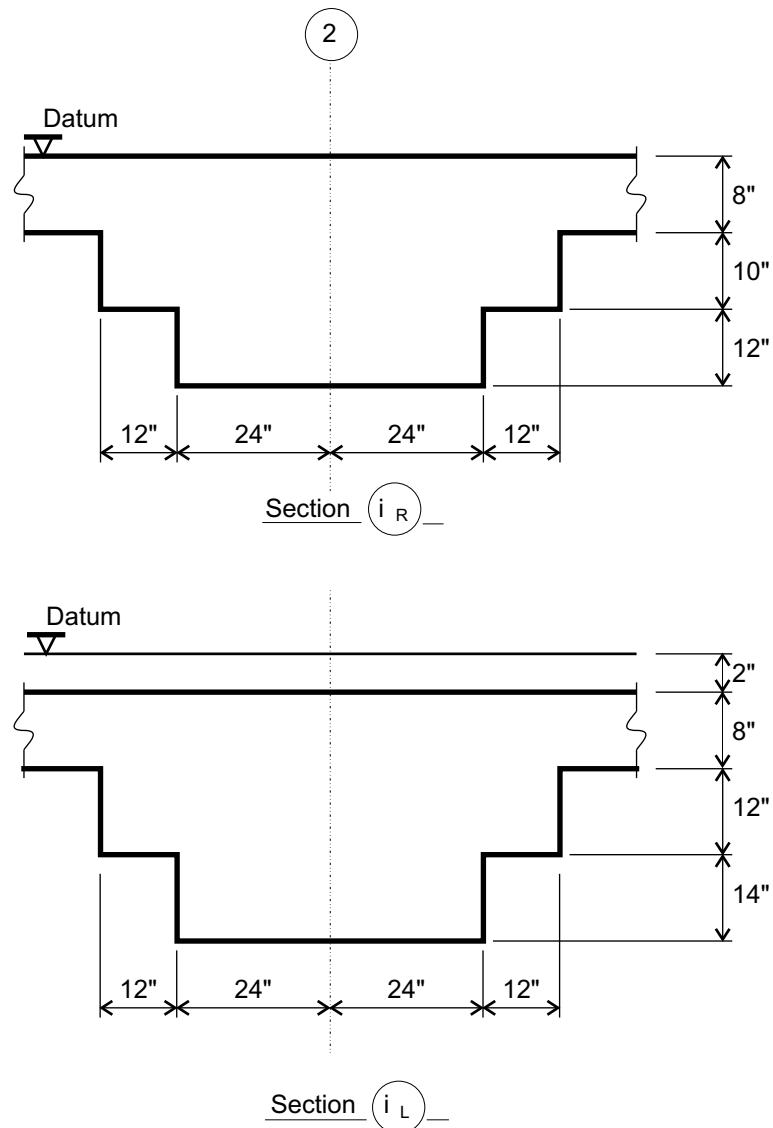

Figure 7.6 - Shearhead Sections

The stiffness of the torsional member is:

$$K_t = \frac{9E_b C_t}{L_2 \left(1 - \frac{c_2}{L_2}\right)^3}$$

(Eqn. 7-3)

where L_2 is either L_{2l} or L_{2r} depending on which torsional member (left or right) at the joint is being evaluated. The total stiffness of the torsional members at a joint is the sum of the stiffnesses K_t for the members on each side.

The constant C_t in Eqn. 7-3 is a function of the cross-sectional dimensions of the torsional member:

$$C_t = \left(1 - 0.63 \frac{x}{y}\right) \frac{x^3 y}{3} \quad \text{(Eqn. 7-4)}$$

where x is the smaller of the rectangular dimensions and y the larger. When a torsional member has more than one cross-section across its L_2 length a weighted average for C_t is used in Eqn. 7-3. For example, in the condition shown in Figures 7.5-7.7, the average C_t for the right torsional member ($L_{2r} = 26' \times 12 = 312''$) would be:

$$C_{t_{avg}} = \frac{C_{t1}(24) + C_{t2}(12) + C_{t3}(276)}{312}$$

where C_{t1} , C_{t2} , and C_{t3} are the calculated C_t values for sections 1 through 3 respectively. Note that **PTData+** assumes that the outermost section 3 (the solid slab) extends all the way to the centerline of the adjacent column at grid line 1.

7.5(b) - The Transverse Beam Torsional Member

PTData+ supports a “transverse beam” torsional member at each joint. The transverse beam has a rectangular web which extends below the cross-sectional profile of the primary equivalent frame beam. The generalized cross section for the transverse beam at an interior joint is shown in Figure 7.8, that for an exterior, or edge joint in Figure 7.9. The “interior joint” cross-section in Figure 7.8 is used for joints 2 through S , and also for joints 1 and $S+1$ when a left or right cantilever, respectively, is present. The “exterior joint” cross-section is used at exterior joints 1 and $S+1$ when no adjacent cantilever is present.

The geometry of the transverse beam is defined by the input values of Y_{tb} and B_w in Figures 7.8 and 7.9. The transverse beam geometry is assumed constant for the full length of its appropriate L_2 value.

The torsional stiffness of each transverse beam at a joint is calculated using Eqn. 7-3. For interior beams C_t is the sum of the individual C_t values (Eqn. 7-4) for each of the four rectangles shown in Figure 7.8. For edge beams the C_t values are evaluated for the two combinations of rectangles shown in Figures 7.9(a) and 7.9(b), and the larger C_t value is used.

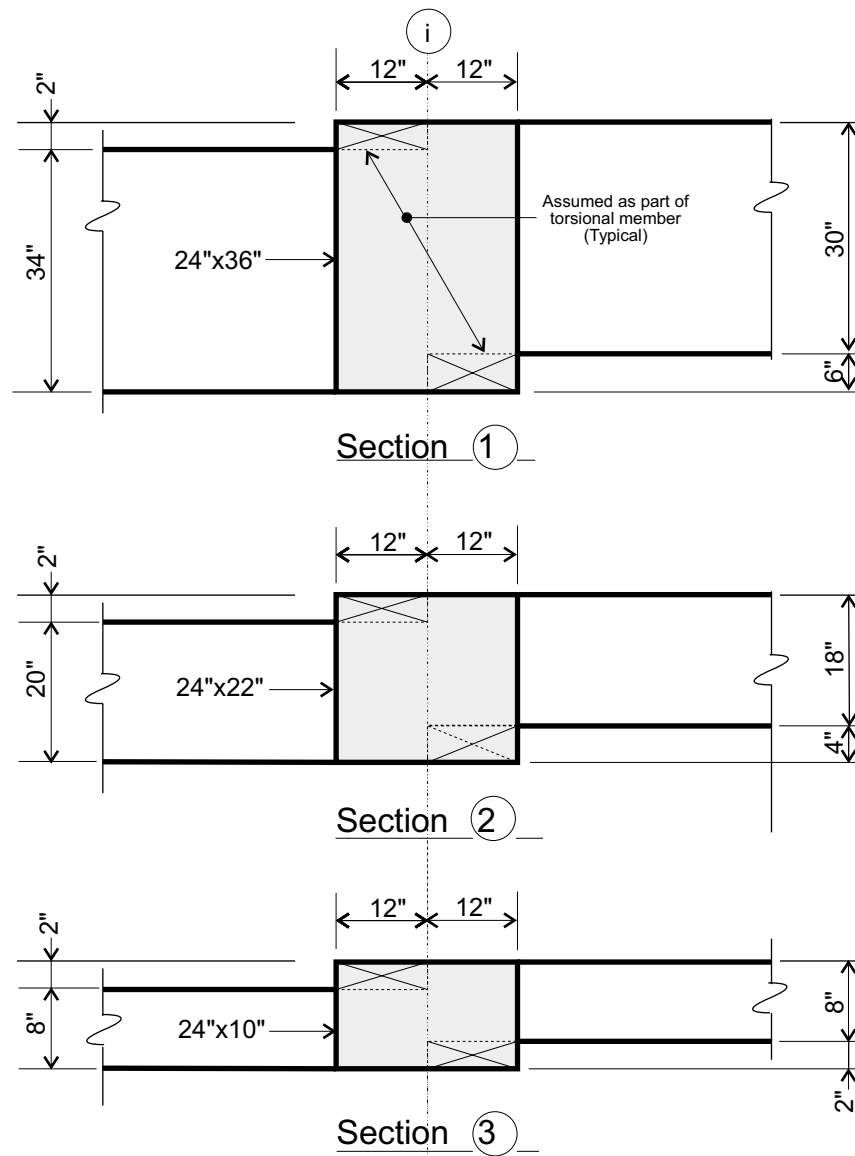

Figure 7.7 - Primary Torsional Beam Cross Sections

7.5(c) - An Adjustment in K_t for "Parallel" Beams

ACI 318-89 Code Section 13.7.5.4 says:

“Where beams frame into columns in the direction of the span for which moments are being determined, value of K_t as computed by [Eqn. 7.3] shall be multiplied by the ratio $[I_{sb}/I_s]$ of moment of inertia of slab with such beam to moment of inertia of slab without such beam.”

which is reasonably straightforward when a) the parallel beam has a constant cross-section (one I value for the whole span), and b) the parallel beams are the same on either side of an interior joint (if they aren't, which one do you use for I_{sb} at the joint between them?). **PTData+** supports up to 20 different I values in one span for an equivalent frame beam, and the beam can of course be different in adjacent spans. Since the Code offers no guidance in these atypical, but very possible, conditions, **PTData+** in these cases uses the following criteria, which seem to be rational:

- If a parallel beam has more than one I_{sb} and/or I_s value in any span, I_{sb} and I_s are based upon a weighted average of the I values considering the length of each different I segment.
- If there are different adjacent parallel beams framing into an interior joint, or if a joint has a parallel beam on one side but not the other, I_{sb} and I_s are based upon the average I_{sb} and I_s values for the two adjacent beams. Note that $I_{sb}/I_s=1$ in a span with no parallel beam.

PTData+ determines that a parallel beam exists in a span when *all beam segments* in that span satisfy one of the following two criteria (refer to Figure 4.1):

- Total member depth h is greater than the largest slab thickness for the beam (t , t_l or t_r), i.e. a beam web extends below the lowest slab soffit.
- The beam is upturned (Type 4).

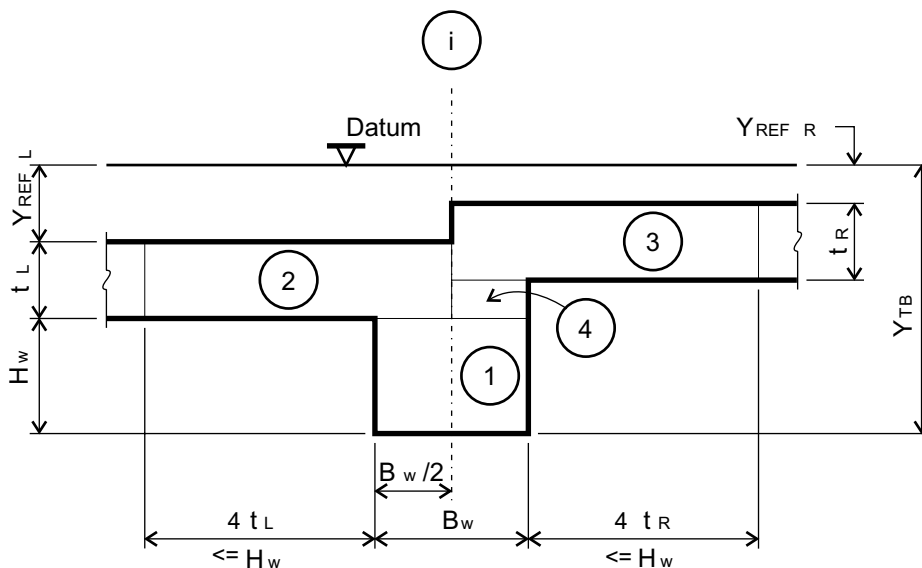

Figure 7.8 - Interior Transverse Beam

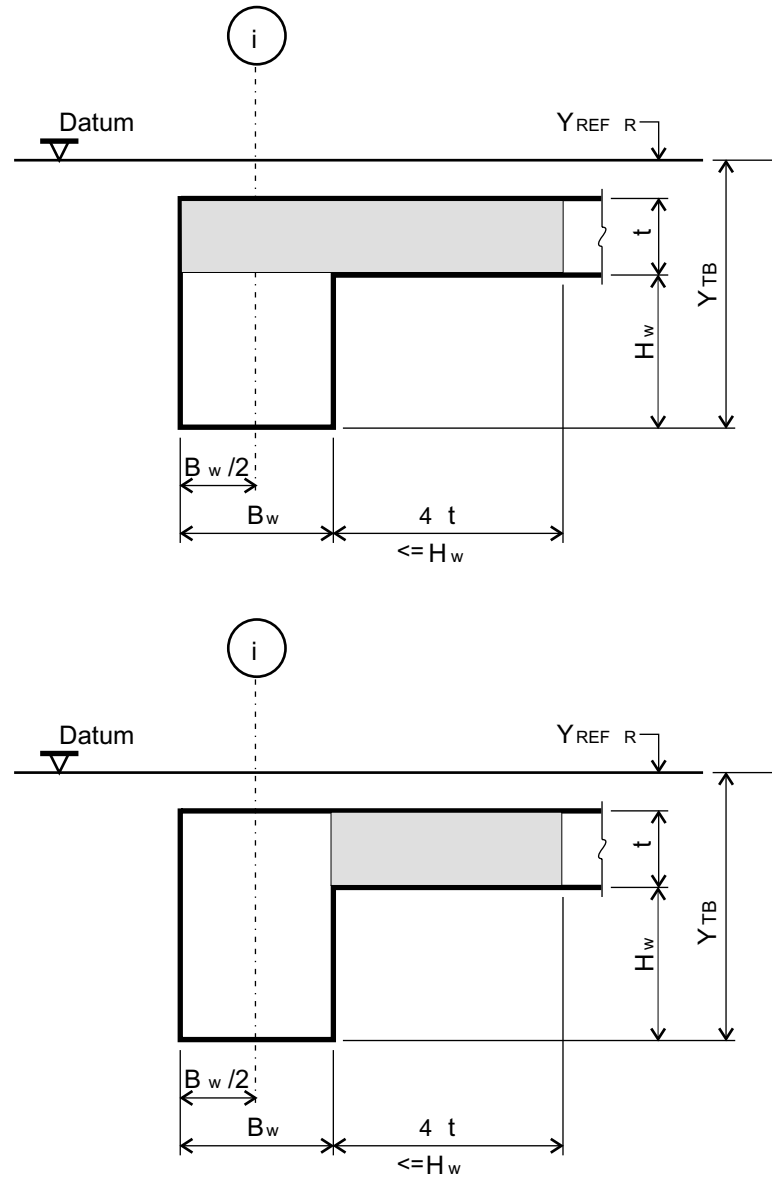

Figure 7.9 - Exterior Transverse Beam

7.6 - The “Equivalent” Column Stiffness K_{ec}

In the equivalent frame method the torsional members are assumed to be a part of the column, rather than the beam. This leads to the concept of an “equivalent” column, one with the flexural stiffness calculated in 7.1 combined with the torsional member stiffness determined in 7.5(a) or (b). To establish the proper relative stiffness between this “equivalent” column and the attached beam, whose stiffness calculation is described in Section 7.4, an equivalent column stiffness K_{ec} is calculated. The flexibility (rotation produced by a unit applied moment) of the equivalent column a_{ec} is equal to the sum of the flexibilities of the actual columns plus the flexibility of the torsional member:

$$a_{ec} = a_c + a_t$$

The flexibility of a member is the inverse of its stiffness, thus:

$$\frac{1}{K_{ec}} = \frac{1}{K_c} + \frac{1}{K_t}$$

which leads to:

$$K_{ec} = \frac{\Sigma K_c}{\left(1 + \frac{\Sigma K_c}{\Sigma K_t}\right)} \quad \text{(Eqn. 7-5)}$$

where K_c is the sum of the two column stiffnesses (one for the top column and one for the bottom column) and K_t is the sum of the two torsional member stiffnesses (one on the left side and one on the right side) at the joint, adjusted if necessary for parallel frame beams per Section 7.5(c).

Chapter Eight

Moments, Shears and Design Points

PTData+ calculates moments and shears (and all other design and analysis parameters) at a specific set of points in each span or cantilever. Some of the points of the set are determined by the user, others are built into the program.

8.1 - User-Controlled Design Points

The user specifies a finite number of equal spaces (P) into which each span or cantilever is divided between support faces. Each end of each space is a design point at which moments and shears are calculated. This is shown in Figure 8.1(a) where the support dimensions (half the column depths) at the left and right ends of the span are $c_{1L}/2$ and $c_{1R}/2$ and the clearspan is called L_{clr} . Each space has a length of L_{clr}/P , and the total number of points is $P+1$, including the faces of supports at the left and right end of the span or cantilever. The left support face is point 0 and the right support face is point P . The default value for P is 10, which results in 11 points in each span or cantilever.

8.2 - Program-Controlled Design Points

PTData+ adds design points to the set as follows. First, a point is added at a distance $h/2$ from each support face, where h is the depth of the beam section immediately adjacent to the appropriate support. This adds two points to each span and one to each cantilever. These points are included because they are the critical locations for shear in most post-tensioned beams. These points are shown in Figure 8.1(b).

PTData+ also adds two points at each cross-section change, one immediately to the left of the change, one immediately to the right of the change. Dead and live load moments and shears at these two points are virtually identical, unless a concentrated moment is applied at the point of section change. However balanced load moments, stresses and reinforcing can be significantly different. These points are shown in Figure 9.1(c). They add $2(N-1)$ points to the set, where N is the total number of cross-section segments in the span or cantilever.

The total number of points within the set for each span of the frame is therefore $P+3+2(N-1)$, and for each cantilever it is one less, $P+2+2(N-1)$.

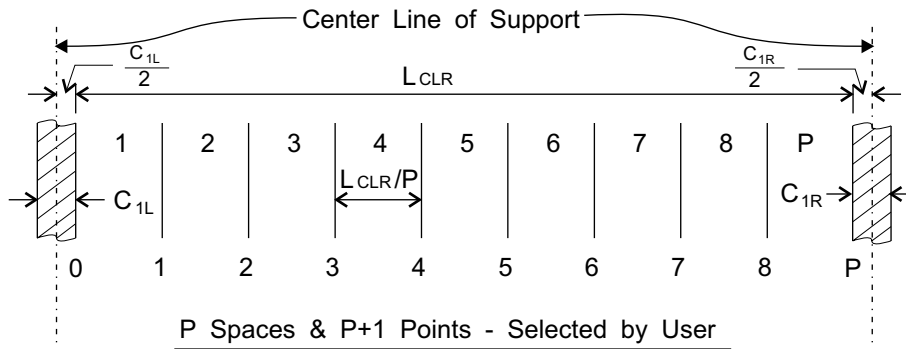

Figure 8.1(a)

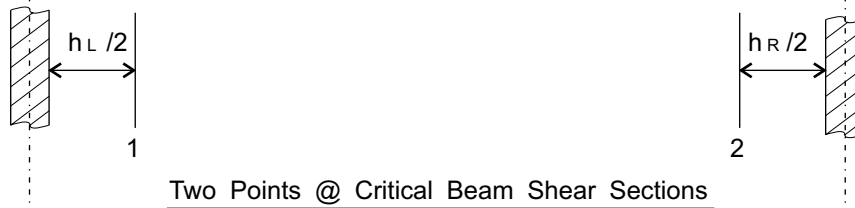

Figure 8.1(b)

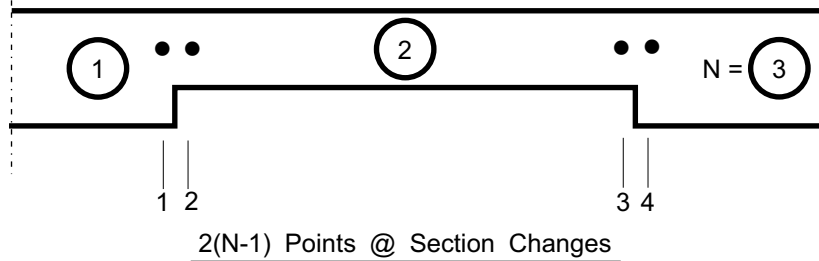

Figure 8.1(c)

Figure 8.1 - Design Points

8.3 - Moments

The single value of dead load moment (M_{dl}), balanced load moment (M_{bal}), and wind moment (M_{wind}) at each design point is calculated. The calculated value of the wind moment is consistent in sign with the signs of the wind moments input at each end of each beam span. **PTData+** knows that the wind moments are reversible and considers both positive and negative values of the wind moment at each design point. The most negative and most positive values possible for “skipped” live load moment are also calculated at each point. To determine these extreme values of live load mo-

ment **PTData+** calculates and examines six moment curves in each span. Each curve is determined by arranging the live load on the frame in the patterns shown in Figure 8.3 to produce the following conditions:

1. Most negative moment at the left end of the span (see Figure 8.3a).
2. Most negative moment at the right end of the span (see Figure 8.3b).
3. Most positive field moment in the span (see Figure 8.3c).
4. Most positive moment at the left end of the span (see Figure 8.3d).
5. Most positive moment at the right end of the span (see Figure 8.3e).
6. Most negative field moment in the span (see Figure 8.3f).

These curves, numbered as above, are shown in Figure 8.2 for a representative span. The dark line at the “top” of the moment envelope defines the most positive live load moment possible at each point, the one at the “bottom” of the envelope defines the most negative live load moment possible at each point.

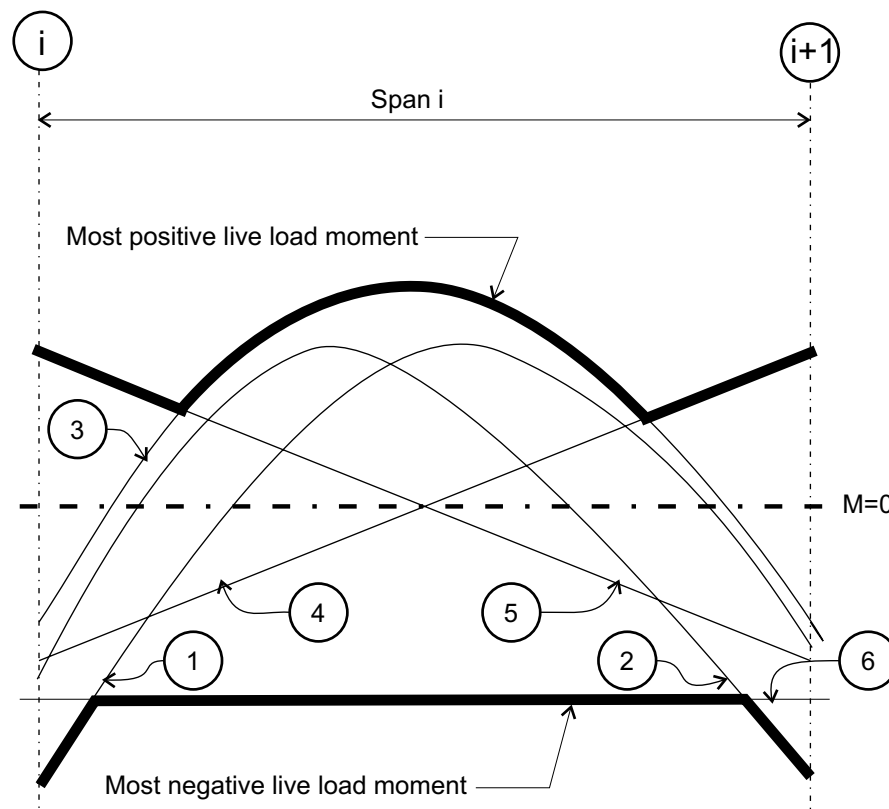

Figure 8.2 - Skipped Live Load Moment Diagrams

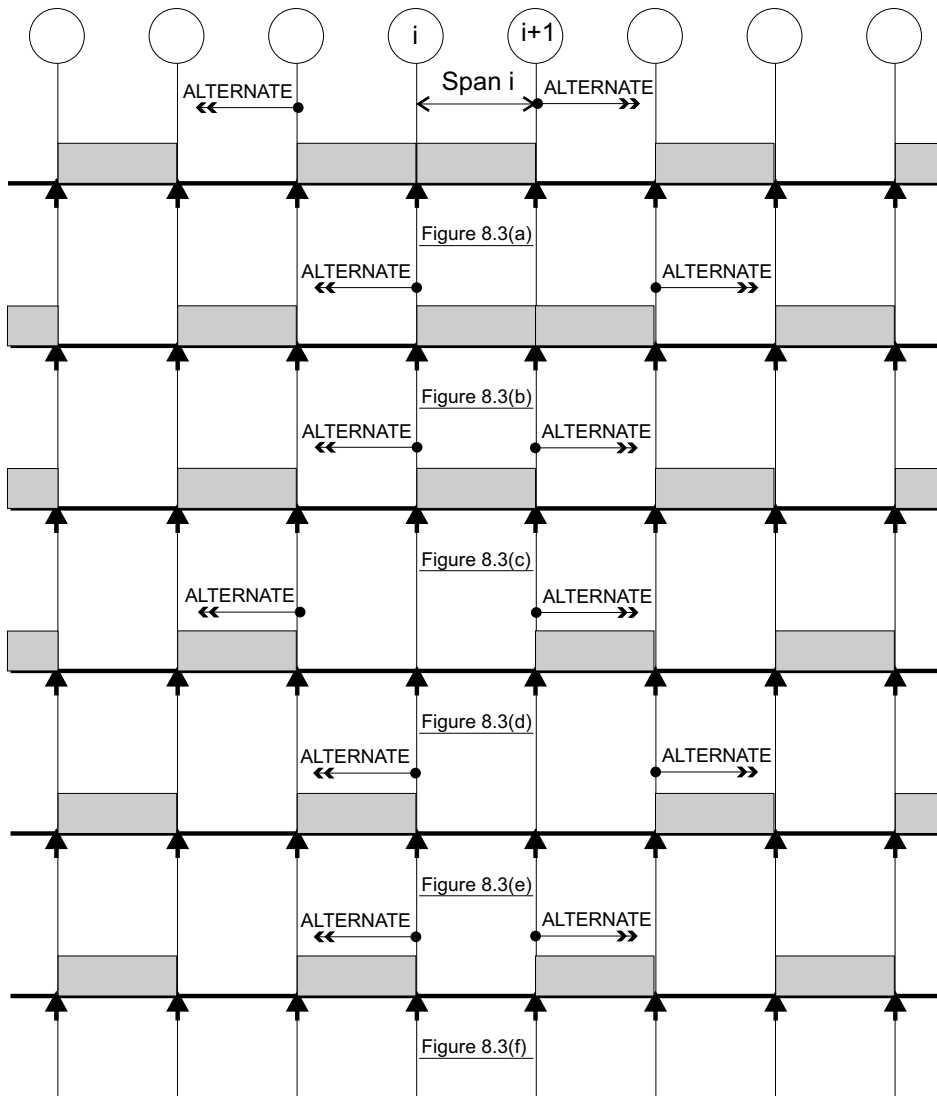

Figure 8.3 - Live Load Patterns

8.4 - Shears

PTData+ calculates the single value of dead load shear (V_{dl}) and wind load shear (V_{wind}) at each design point, and the **largest** possible value of live load shear (V_{ll}). The sign of the calculated wind load shear is consistent with the signs of the wind moments input at the ends of each beam span. **PTData+** considers the wind load shears to be reversible (i.e., they are always **additive** to the shears due to dead and live loads in determining the demand shear).

The maximum live load shear values are determined by arranging the live load on the frame and calculating the shears associated with the loading pattern which produces the following conditions:

1. Most negative moment at the left end of the span.
2. Most negative moment at the right end of the span.
3. Most positive field moment in the span.

The maximum possible shear at each point is used in **PTData+** shear calculations, along with the statically consistent moment associated with that shear.

This page intentionally left blank

Chapter Nine

Design by PTDATA+

9.1 - General Design Theory For Post-Tensioned Concrete

The selection of prestress force and tendon profile in indeterminate post-tensioned concrete frames is normally based upon a limiting criteria of flexural concrete stress under service loads. Prestress forces and profiles are selected in each span and cantilever such that the resultant flexural stresses under service (unfactored) dead and live loads at all points throughout the frame are less than or equal to the maximum permissible values specified by the code. In well-proportioned frames tensile stresses are the limiting criteria, i.e., the limiting value of tensile stress will typically be reached before the limiting value of compressive stress. Designers are cautioned against the use of any post-tensioned concrete member whose design is controlled by flexural compression, rather than tension.

Wind moments are not considered for any service or transfer load condition (concrete flexural stresses or deflections). When present, they are considered **only** in strength calculations (flexural strength and shear strength). They are also included as a part of the calculated factored column moments.

The optimum design of a post-tensioned frame, from standpoints of economy and performance, is one where the maximum concrete flexural stress is equal to the maximum value permitted by code. Using less prestress force than this maximum value will increase the flexural stresses beyond that permitted; using more prestress force is inefficient economically and invites restraint-to-shortening problems.

In some designs the prestress force and profile may be limited by a criteria other than flexural concrete stress. This limiting criteria could be an arbitrary or code-specific minimum average axial compression (F/A), a static deflection criteria, or it could be a limit on the amount of load balanced by the tendons.

Once the prestress force and profile is determined by the service load condition, the design is completed by selecting the required amounts of unstressed reinforcing. Criteria which determine this reinforcing include the following, **none of which** affect the “optimum” prestress force and profile already established:

9.1(a) - Flexural Strength

At all points the frame beams must have a useable flexural capacity equal to or greater than the applied “ultimate” moment (the “demand moment”) at that point. The demand moment is determined considering code-specific factors of safety, or load factors, applied to the dead, live, and wind loads. **PTData+** considers the following eight combinations of dead, live, and wind loads in all calculations for flexural strength, shear strength, and factored column moments:

$$U = KDL(D) + KLL(L^+) + M_2 \quad \text{(Eqn. 9-1)}$$

$$U = KDL(D) + KLL(L^-) + M_2 \quad \text{(Eqn. 9-2)}$$

$$U = KCOMB(KDL1(D) + KLL1(L^+) + KW1(W)) + M_2 \quad \text{(Eqn. 9-3)}$$

$$U = KCOMB(KDL1(D) + KLL1(L^+) - KW1(W)) + M_2 \quad \text{(Eqn. 9-4)}$$

$$U = KCOMB(KDL1(D) + KLL1(L^-) + KW1(W)) + M_2 \quad \text{(Eqn. 9-5)}$$

$$U = KCOMB(KDL1(D) + KLL1(L^-) - KW1(W)) + M_2 \quad \text{(Eqn. 9-6)}$$

$$U = KDW(D) + KW2(W) + M_2 \quad \text{(Eqn. 9-7)}$$

$$U = KDW(D) - KW2(W) + M_2 \quad \text{(Eqn. 9-8)}$$

Where *KDL*, *KLL*, *KW1*, *KW2*, *KDW*, *KCOMB*, *KDL1*, and *KLL1* are user-controlled load factors applied to the dead (D), live (L), and wind (W) loads. Default (as-shipped) values for these eight load factors are 1.4, 1.7, 1.7, 1.3, 0.9, 0.75, 1.4, and 1.7 respectively.

Inelastic moment redistribution in accordance with ACI 318 requirements (see Chapter 12) is applied to the elastic moments produced by factored **gravity loads** only (the first two equations listed above). When live load is skipped (arranged to produce the maximum and minimum moments possible at each point), inelastic moment redistribution is applied **only** to the **maximum** moment case (load patterns a, b and c in Figure 8.3). Moment redistribution is **not applied to minimum** moment cases (load patterns d, e, and f in Figure 8.3) **nor to any load combination which includes wind moments** (the last six equations listed above).

Prestressed and longitudinal unstressed reinforcing (normally mild reinforcing steel) contribute to the flexural capacity at each point in the frame, and unstressed reinforcing must be supplied at any point where the prestressed reinforcing is not sufficient to develop the demand moment. The Uniform Building Code also requires, when prestressing tendons are unbonded, the unstressed reinforcing *alone* (without the tendons) must provide a flexural capacity equal to the moment produced by unfactored dead loads and 25% of the unfactored and unreduced live load.

9.1(b) - Cracking Moment

The ACI code requires that the flexural capacity of all prestressed concrete members be at least 1.2 times greater than the “cracking moment (M_{fr})” at that point (ACI318-89 Section 18.8.3), unless the flexural and shear capacities are twice that required by applied factored loads. The cracking moment M_{fr} is defined as the moment which produces a flexural tensile stress f_r of $7.5\sqrt{f'_c}$. At the top beam fiber:

$$M_{fr} = S_{mt}f_r + \frac{S_{mt}F}{A} + M_{bal}$$

At the bottom beam fiber:

$$M_{fr} = S_{mb}f_r + \frac{S_{mb}F}{A} + M_{bal}$$

This requirement has been in the ACI code since 1963, the first year in which prestressed concrete appeared. It addresses a hypothetical condition in deep, lightly prestressed determinate beams with bonded tendons. Such beams have large cracking moments and the appearance of the first crack could theoretically transfer enough force into the tendons to fail them suddenly in tension. The requirement was intended to provide a margin of strength beyond the cracking moment to warn of impending flexural failure in this unique type of prestressed member.

In the author’s opinion, the conditions which generated this requirement do not exist in any prestressed concrete member with unbonded tendons, determinate or indeterminate. By definition, there is no strain compatibility between the tendon and the concrete in an unbonded tendon, thus a sudden large transfer of force to the tendon at first cracking does not occur. The stress in an unbonded tendon remains relatively constant up to first cracking, at which point it begins to gradually increase up to a maximum which is substantially less than its ultimate tensile stress.

The requirement also has no beneficial application in any indeterminate prestressed concrete member, bonded or unbonded, where the inherent redundancy precludes a flexural failure without warning.

The author's opinion notwithstanding, the ACI code applies this requirement to all prestressed concrete members, not just to the unusual ones it was intended to remedy. Committee work has been under way for some time to remove or relax the requirement, however it remains in ACI 318-89 exactly as it was in ACI 318-63. It is a commonly ignored code requirement, almost universally ignored in two-way slab systems. ACI/ASCE Committee 423 has recommended that the requirement be waived in all members with unbonded tendons since 1983 (*Recommendations for Concrete Members Prestressed with Unbonded Tendons*, ACI423.3R-83 and 89, Sections 3.2.1 and 3.3.2). Nonetheless, ignoring this requirement is a technical violation of the ACI code and could put the designer at some legal risk.

Application of this criteria significantly affects the required amount of longitudinal unstressed reinforcing. This additional reinforcing, for the vast majority of prestressed structures, adds only cost with virtually no benefit, other than a higher factor of safety than required for any other type of concrete construction.

This cracking moment criteria can be applied or waived by **PTData+**. If the criteria is waived, **PTData+** will show the user the design points at which cracking moments *would have controlled* the reinforcing steel had the criteria been applied.

9.1(c) - Arbitrary Minimums

For prestressed frames with **unbonded** tendons the ACI code requires some minimum amount of unstressed bonded longitudinal reinforcing. The amount and location of this reinforcing is a function of whether the frame is of one-way or two-way construction. Tests have shown that this minimum amount of bonded reinforcement provides unbonded members with crack distribution, ductility, and general flexural behavior equivalent to or better than prestressed members with bonded tendons or nonprestressed members. Following are the specific requirements for **minimum** bonded reinforcement in one-way and two-way members with unbonded tendons:

9.1(c)1 - One-Way Beams and Slabs

The code requires the following minimum bonded reinforcement in one-way beams and slabs:

$$A_s = 0.004A_g$$

where A_g is the area of that part of the cross-section between the flexural tension face and the center of gravity of the cross-section. Note that for cross-sections which are not symmetrical about their centroidal axis (like T-beams), different amounts of minimum reinforcement are required at the top and the bottom of the member. The code

states that this reinforcement shall be *uniformly distributed over precompressed tensile zone as close as practicable to extreme tension fiber*. The code further states that this minimum reinforcement is required regardless of service load stress conditions.

PTData+ interprets these requirements as follows. At each design point the most negative and most positive unfactored total load moments ($M_{dl} + M_{ll}$) are determined by adding the most negative and most positive unfactored live load moments to the unfactored dead load moment at the design point. If both of these extreme total load moments are negative, the minimum reinforcement is required only at the top of the member. If both of the total load moments are positive, the minimum reinforcement is required only at the bottom of the member. If one moment is negative and one positive (a reversal of moment can occur at the design point), the minimum reinforcement is required at **both** the top and the bottom of the member.

9.1(c)1 - Two-Way Slabs

The code requires minimum reinforcement at the bottom of two-way slabs (in positive moment areas) only when the service load flexural tension stress exceeds $2f_c$. In that case, the minimum area of bonded reinforcement at the bottom of the slab (for the full tributary) is:

$$A_s = \frac{f_{bot}^2 Bh}{f_y (f_{top} + f_{bot})}$$

where:

f_{top} = Compressive stress at the top fiber

f_{bot} = Tensile stress at the bottom fiber

The minimum specified length of these bottom bars is one-third the clearspan length, centered in the span. While it is not clearly stated by the code, this presumably means that the **largest amount** of minimum steel required **anywhere** in the positive moment region shall have this minimum length.

In negative moment areas (over columns) the minimum area of bonded reinforcement required at the top of the slab is:

$$A_s = 0.00075hl_1$$

where:

l_l = The length of the span in a direction *parallel* to that of the reinforcement being determined.

The code does not address the condition of different adjacent spans at a column. In this (common) case **PTData+** bases the term on the average of the two adjacent spans, except at the first and last joints. There **PTData+** bases on the cantilever span or the first (or last) span, depending on whether the design point is in the cantilever or the adjacent first or last span.

The code requires that *minimum* top bars extend into the span at least one sixth of the clearspan from the support face. Any top bars necessary for *strength* must satisfy development requirements of ACI Chapter 12, and as a result may extend substantially farther into the span than the minimum length stated above.

9.1(d) - Shear Strength

At all points the frame beams must have a useable shear strength equal to or greater than the applied “ultimate” shear (the “shear demand”) at that point. Web reinforcing (stirrups) may be required to satisfy this criteria. At columns of two-way systems the combined shear stresses acting on the “critical section” caused by direct shear and unbalanced moment must be limited to certain permissible values. See Chapter 14 for a detailed description of the shear design procedure.

9.2 - The Computer-Generated “Automatic” Design

PTData+ generates an “automatic” design of prestress force and tendon profile for each frame based upon the input data and criteria. The design is limited by maximum permissible flexural *tensile stress* in the concrete under service dead and live loads (*excluding* wind loads). The following procedure is used by **PTData+** to design the prestress force and profile:

First, **PTData+** determines, for each span and cantilever, the tendon profile with the maximum possible sag. This profile has minimum concrete cover at high and low points. For double-harp tendon profiles with two low points **PTData+** determines the controlling lowpoint, and the resultant profile, based upon the input ratio of P_2/P_1 (see Sections 5.6 and 5.7). This profile, for each span or cantilever, results in the maximum possible equivalent tendon loads for any given prestress force.

Next, **PTData+** calculates the static dead load moment diagram for each span and cantilever. This is a simple-span, determinate moment diagram based only upon the dead loads present in each span. The magnitude and location of the maximum simple-span dead load moment is determined. Figure 9.1(a) shows a hypothetical sim-

ple-span dead load moment diagram for Span i where the maximum dead load moment M_{dl} occurs at a distance x from the left support centerline. Figure 9.1(b) shows the hypothetical tendon profile for the same Span i , with a sag (offset from the chord) of a_x at the point of maximum dead load moment M_{dl} . A harped profile is shown in Figure 9.1(b) however the procedure is identical for *any* profile. An initial prestress force is calculated for Span i as follows:

$$F_i = \frac{0.8M_{dl}}{a_x} \quad \text{(Eqn. 9-9)}$$

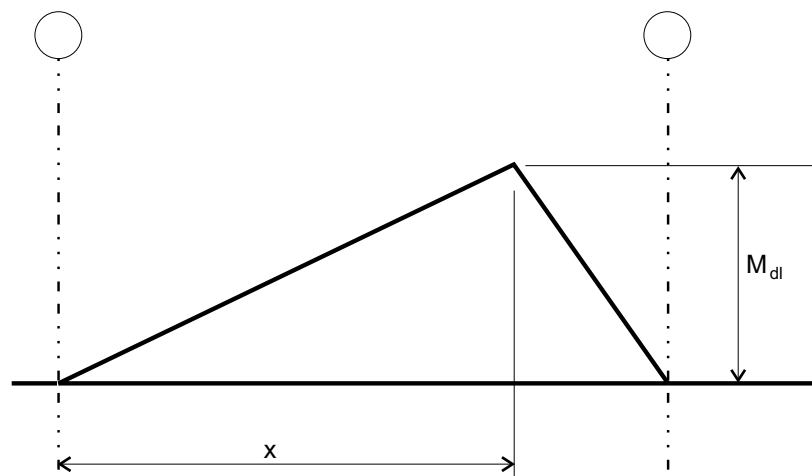

Figure 9.1(a) - Simple-Span Dead Load Moments

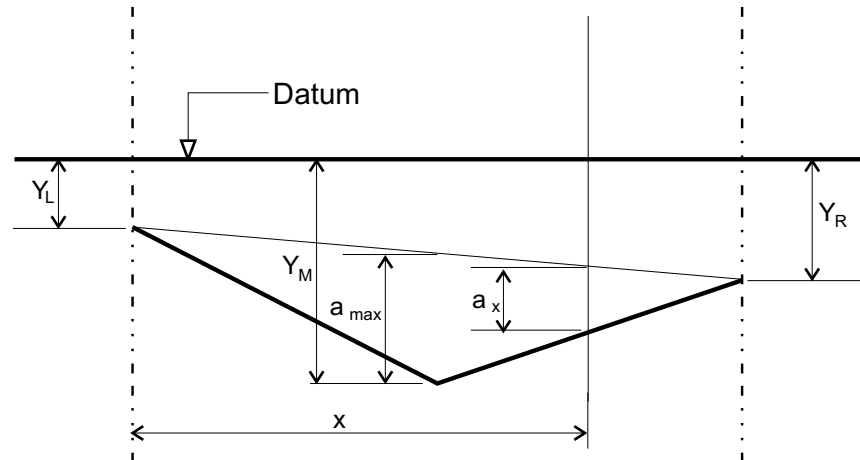

Figure 9.1(b) - Tendon Profile

Figure 9.1 - Finding the First Force and Profile

F_i represents the smallest possible force in Span i which will “balance” an arbitrary 80% of the maximum static dead-load moment M_{dl} , using a tendon profile with maximum possible sag. F_i values as described are calculated for each span and cantilever of the frame.

Next the forces F_i are “sorted” in accordance with the input values of left and right endspans. For example, Figure 9.2 shows a seven-span frame with 2 endspans specified at both left and right ends. Spans 3 through 5 are “through” spans, spans which are not endspans. The final “sorted” force in all through spans is the largest of their individual F_i forces. In our example, the largest force in any through span is 300 kips, which occurs in Span 5. 300 kips is therefore selected for all three through spans 3-5. This 300 kip “through” force must also pass through the endspans in order to be stressed at the two ends of the frame.

In endspans, prestress force is allowed to increase progressively outwards to the exterior stressing points. In Span 2, a left endspan, $F_2=500$ kips, therefore a 200 kip tendon is added to Span 2, extending through Span 1 to grid line “1”. $F_1=600$ kips, therefore a 100 kip tendon is added to Span 1, making the total force in Span 1 600 kips. At the right end of the frame, Span 6, a right endspan, requires 600 kips, therefore a 300 kip tendon is added in Span 6, extending through Span 7 to grid line “8”. F_7 is 500 kips, however the 300 kip through tendon plus the 300 kip added tendon from Span 6 means that the final force in Span 7 can be no less than 600 kips, which is selected as F_{sort} for Span 7.

The final sorted forces F_{sort} , and the arrangement of added and through tendons to achieve these forces, are shown in Figure 9.2, which also indicates whether each span is a “controlling” or a “non-controlling” span. A controlling span is a span in which $F_{sort}=F_i$. A non-controlling span is one in which F_{sort} is greater than F_i . Controlling spans have a tendon profile with maximum sag. In non-controlling spans, since the prestress force is larger than that required to balance $0.8M_{dl}$ with maximum sag, the sag is reduced by the ratio F_i/F_{sort} .

The above method results in an initial selection of prestress force and tendon profile in each span and cantilever which is consistent with the specified left and right endspans, and which “balances” 80% of the static dead load moment in each span. The profile which has been selected in this manner remains the final tendon profile in the computer-generated design. Using this profile, **PTData+** adjusts the prestress force throughout the frame until the maximum concrete bending tensile stress is between 97% and 100% of the allowable tensile stress.

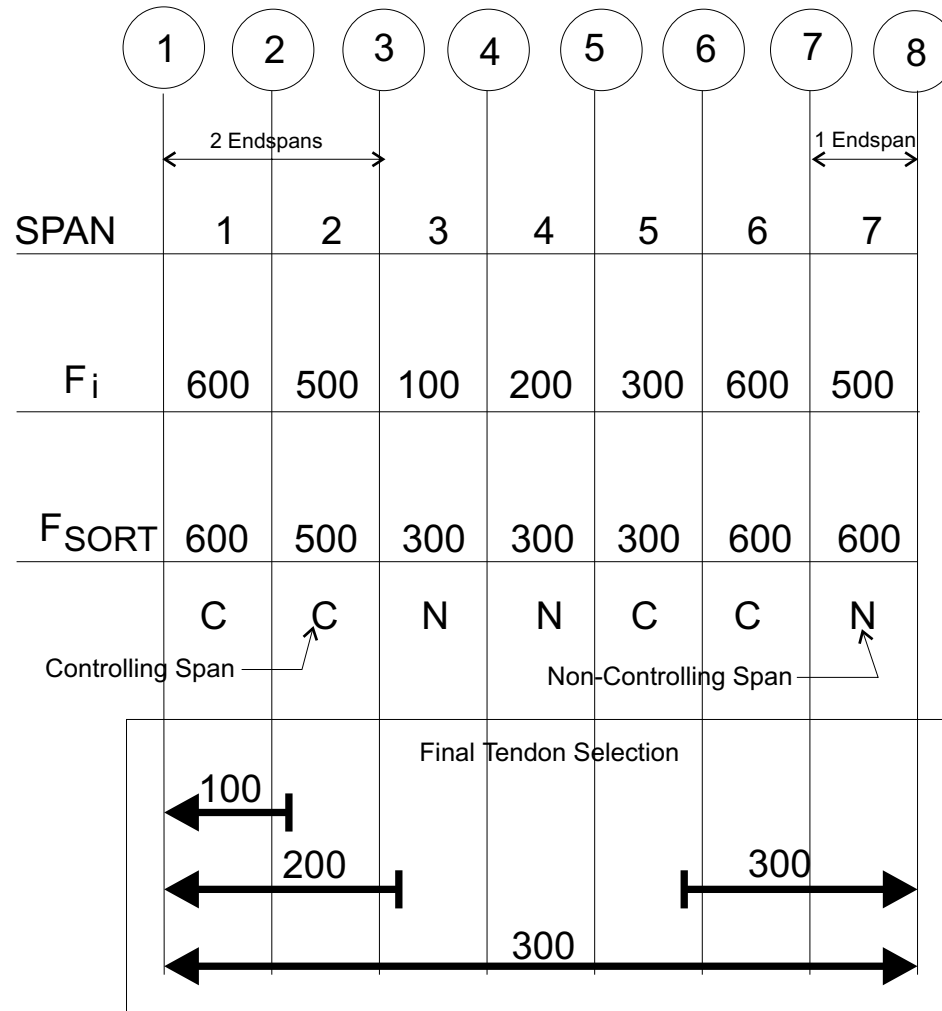

Figure 9.2 - Sorting the Forces

9.2(a) - Special Conditions at Cantilevers

In non-controlling *spans* the sag is reduced by raising the tendon lowpoint, or lowpoints, with the two highpoints remaining at minimum cover. In a non-controlling *cantilever*, however, the sag can only be effectively reduced by lowering the highpoint. If the non-controlling cantilever is adjacent to a controlling backspan, the backspan sag is also reduced since one of its highpoints has changed. The minimum force F_i in the backspan will no longer balance the desired 80% of the static dead load moment in the backspan, since it was based upon maximum sag. The backspan force must therefore be increased to account for the reduced sag. Since **PTData+** requires that the prestress force be the same in cantilevers and adjacent backspans, the cantilever force is too high and the cantilever sag must be reduced by

again lowering the highpoint. As can be seen, this leads to an iterative procedure of reducing the cantilever sag, increasing the backspan force, reducing the cantilever sag, etc., until the unique cantilever highpoint is found which results in the desired force and profile in both the cantilever and the backspan.

PTData+ performs this iteration in the case of a non-controlling cantilever with a controlling backspan. The resulting cantilever support highpoint is the only highpoint in the computer-generated design which is not established by minimum concrete cover.

9.3. - Iteration To The Final Design

With the initial force and profile determined as described above, **PTData+** calculates the equivalent loads, moments, and concrete bending stresses throughout the frame. If the maximum concrete tensile stress is between 97% and 100% of the allowable tensile stress, the design is complete as is. If the maximum concrete tensile stress in the frame is above or below that acceptable range, however, **PTData+** begins an iteration process which modifies the prestress forces, and all parameters related to the prestress force, on each iteration until the maximum stress falls within the acceptable range. If the maximum stress is higher than the acceptable range, prestress force is added. If the maximum stress is lower than the acceptable range, prestress force is reduced. This adjustment of prestress force is done for both through tendons and added tendons, depending on the maximum stress condition in through and end spans. Prestress force will not be reduced below that which produces, anywhere in the span, the minimum average compression value (F/A) specified by the user.

For most post-tensioned frames, this iterative process will result in an efficient and practical design for prestress force and tendon profile in both controlling and non-controlling spans. The computer-generated design may be modified by the user in the interactive mode (the “Review Menu”). Each time a change is made in any force or any profile, **PTData+** recalculates all values which are a function of the prestress force and/or profile, including unstressed reinforcement.

Chapter Ten

Flexural Stresses

Using the method described in Section 2.1, **PTData+** calculates the concrete flexural stresses at the top and bottom beam fibers under two loading conditions, one under unfactored dead and live loads (the service load condition), the other at the time of stressing, the “transfer” condition where only concrete dead loads are present. Wind moments are not included in the calculation of transfer or service load concrete flexural stresses.

10.1 - Concrete Flexural Stresses at Service Loads

In the service load condition all prestress losses are assumed to have occurred and the prestress force is at its “effective” level. Stresses are calculated at the top and bottom beam fibers under the action of unfactored dead and live loads, with the live loads arranged so as to produce the most negative and the most positive moments possible at each point.

At each design point along the length of the beam the most negative and the most positive moments possible are calculated. The bending stresses are then calculated at the top and bottom beam fibers for each of these extreme moments. The bending stress data can be presented graphically in the form of four curves as shown in Figure 10.1, which represent stresses in a 3-span frame with equal spans of 60 feet. The four curves show the bending stresses under service loads at the top and bottom fiber, each under the most positive or most negative moment possible. For example, the curve labeled “Bot Fiber (Max M_-)” shows the stresses at the bottom beam fiber under the most negative moment possible. The envelope formed by these four curves is the entire range of beam concrete stresses possible throughout the frame. It should be noted that when the live load is uniformly applied, not “skipped”, all four curves are the same.

10.2 - Concrete Flexural Stresses at Transfer of Prestress

PTData+ calculates the concrete bending stresses at “transfer”, immediately after the tendons have been stressed. In this condition, **PTData+** assumes that the load acting on the frame is the weight of the concrete ONLY, with no live load and no superimposed dead loads. In the transfer condition, the “initial” prestress forces are assumed to be 7/6 times the effective prestress forces used to calculate service load stresses (Section 10.1). The ratio of 7/6 for initial to effective prestress forces assumes an initial tendon stress of $0.7f_{pu}$ and an effective tendon stress of $0.6f_{pu}$, with the differ-

ence, $0.1f_{pu}$, assumed for prestress losses. While this ratio may tend to slightly overestimate initial tendon forces, the overestimation is conservative and is sufficiently accurate for the calculation of transfer stresses.

Transfer stresses rarely control the design of post-tensioned concrete members, and any which are should be critically evaluated. Post-tensioned members controlled by temporary loading conditions, such as transfer stresses, normally do not make economic sense and are often over-prestressed and susceptible to restraint-to-shortening problems aggravated by excessive prestress force.

Concrete Bending Stresses

(1 KSI=6.895 MPa; 1 ft=0.3048 m)

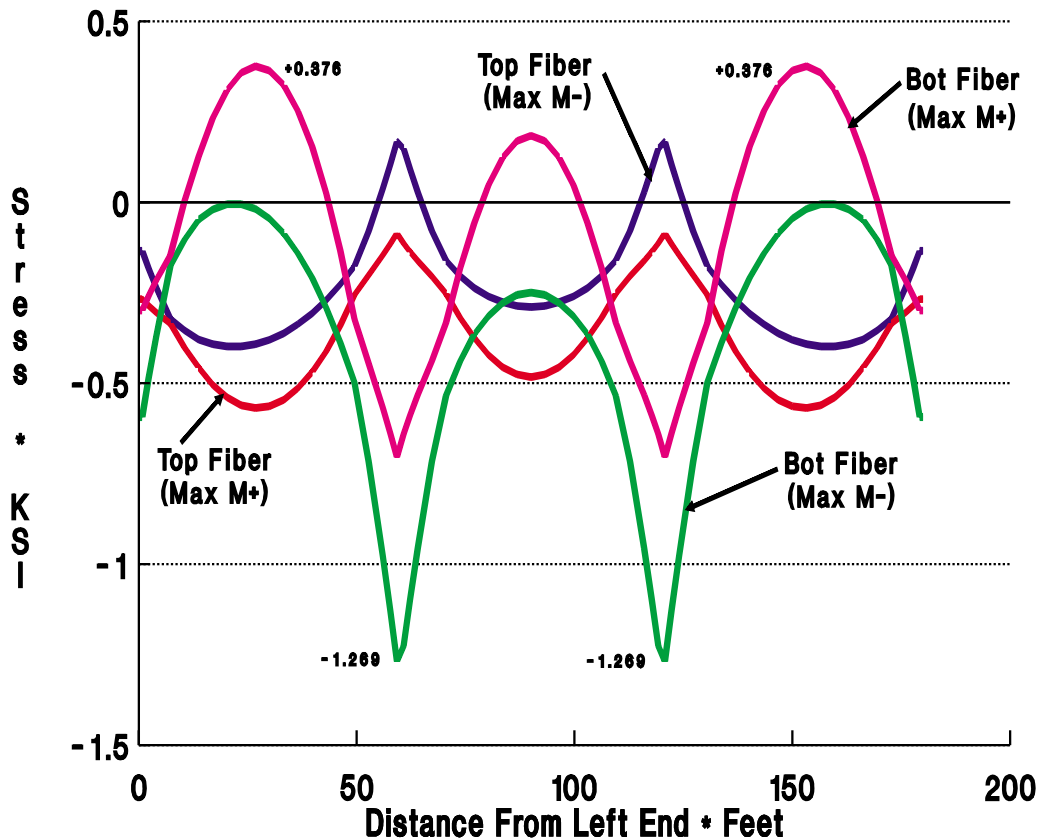

Figure 10.1

Chapter Eleven Flexural Strength

11.1 - Strength Theory in Prestressed Concrete

Figure 11.1 shows a freebody diagram of a prestressed concrete beam at nominal (ultimate) strength. For horizontal equilibrium at section A-A:

$$C = T$$

and for moment equilibrium:

$$Ty = M_{design}$$

where M_{design} is the moment which equilibrates the applied external loads and reactions (including secondary reactions, if any). The distance separating T and C can be expressed as:

$$y = \frac{M_{design}}{T}$$

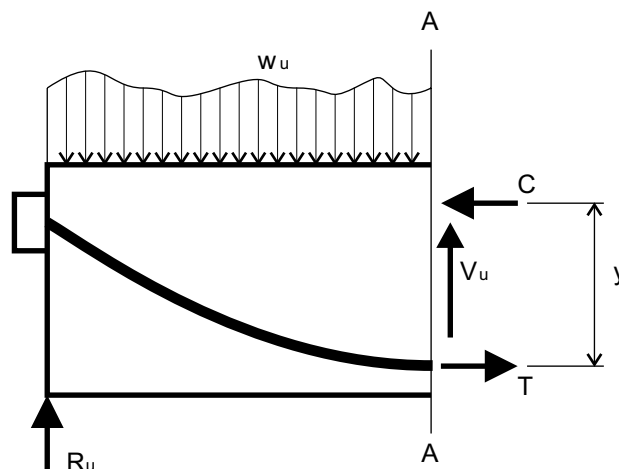

Figure 11.1 - Strength Freebody

The location of the tensile force T is fixed and always located at the centroid of the tension reinforcement, which may be prestressed or unstressed or a resultant combination of the two. The location of the compression force C varies in accordance with the applied moment M_{design} . T and C produce stresses on the cross-section, which must be limited to certain allowable values so the section will not fail under the applied moment M_{design} . The tension force T causes tensile stresses in the tension reinforcement A_s and A_{ps} . The compression force C causes compressive stresses in the concrete and in any reinforcement located in the compression area of the cross-section.

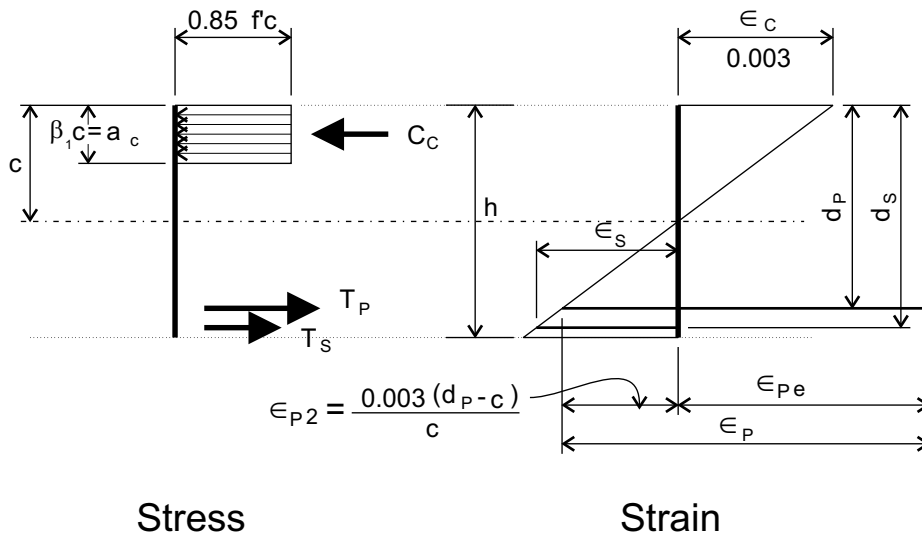

Figure 11.2 - Stresses & Strains

The magnitudes of the stresses acting on section $A-A$ can be calculated by considering the strains acting there, assuming that plane sections remain plane under bending. Increased moment produces increased curvature until a failure condition occurs in either the concrete or the steel. For most reinforced concrete sections, prestressed or non-prestressed, the concrete will reach its maximum strain before the steel has ruptured in tension. This maximum concrete strain is defined as 0.003 inches/inch. The steel stresses at nominal strength are typically controlled by the condition of maximum concrete strain. Tests have shown that when the concrete is at its maximum fiber strain, the distribution of concrete stresses and strains can be modeled with reasonable accuracy using a rectangular “block” of compressive stress in the concrete as shown in Figure 11.2. Note in Figure 11.2 that the uniform concrete stress in the “compression block” is $0.85\sqrt{f'_c}$, and the depth of the block is $\beta_1 c$, where c is the distance from the extreme compression fiber to the “neutral axis”, or point of zero strain.

11.2 - The Precise Stress-Strain Method

To determine the bending strength M_n of a rectangular cross-section reinforced with tension reinforcement only (bonded prestressed tendons and unstressed reinforcing steel), one needs the information shown in Figure 11.2 and a stress-strain diagram for the prestressed and unstressed steel. The trial-and-error procedure is:

1. Assume the concrete is at maximum strain of 0.003
2. Assume a value for c .
3. Calculate C :

$$C = 0.85f'_c B \beta_1 c$$

4. Calculate ε_p and ε_s from similar triangles. Note that ε_p includes ε_{pe} , the “effective” strain in the prestressed steel with no applied moment **and** ε_{ce} , the compressive strain in the concrete at the level of the prestressed steel **with no applied moment**. For practical purposes ε_{ce} may be ignored. Typically ε_{ce} is less than 5% of ε_{pe} , which is probably smaller than the degree of precision to which ε_{pe} is normally estimated:

$$\varepsilon_s = 0.003 \frac{d_s - c}{c}$$

$$\varepsilon_p = \varepsilon_{p2} + \varepsilon_{pe} + \varepsilon_{ce} = 0.003 \frac{d_p - c}{c} + \varepsilon_{pe} + \varepsilon_{ce}$$

5. Calculate $T = T_p + T_s$:

$$T_p = A_{ps} f_{ps}$$

$$T_s = A_s f_s$$

where f_{ps} and f_s are stresses obtained from appropriate stress-strain diagrams, and which correspond to ε_p and ε_s respectively.

6. Compare T and C . If close enough:

$$M_n = T_p \left(d_p - \frac{a_c}{2} \right) + T_s \left(d_s - \frac{a_c}{2} \right)$$

if not, assume another c and start over at step 3.

For example, consider the rectangular beam shown in Figure 11.3. The capacity M_n of this cross-section can be calculated using stress-strain methods and the iterative method described above. Figure 11.4 shows the representative stress-strain diagrams for prestressed and unstressed steel. Following are the calculations for M_n using the iterative stress-strain method, which in this case required only two iterations starting with a guess of 8 inches for c and a value for p_e of $170/28000=0.006$ in/in. The calculations yield an actual c value of 9" and a calculated moment capacity of 424 foot-kips.

	c	C	ϵ_{pe}	ϵ_{p2}	ϵ_p	ϵ_s	f_{ps}	f_s	T_p	T_s	T
	in	k	in/in	in/in	in/in	in/in	ksi	ksi	k	k	k
1	8	277	.0060	.0045	.0105	.0053	255	60	234	76	310
1	9	311	.0060	.0037	.0097	.0043	250	60	229	76	306

$$a_c = 0.85 \times 9 = 7.65''$$

$$M_n = \frac{1}{12} \left[229 \left(20 - \frac{7.65}{2} \right) + 76 \left(20 - \frac{7.65}{2} \right) \right] = 424 \text{ ft - kips}$$

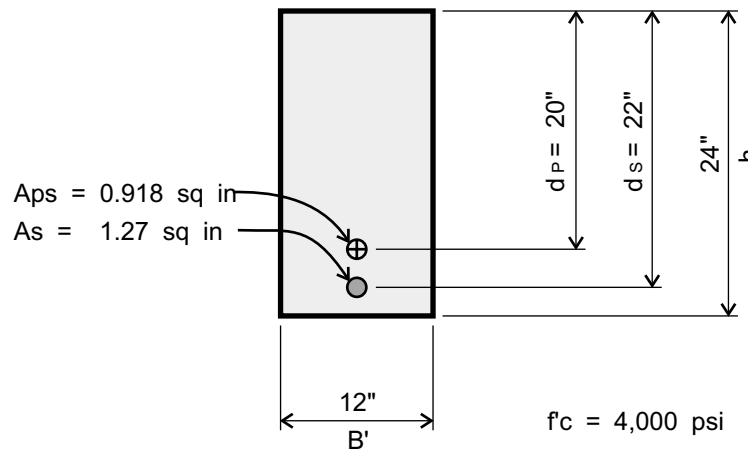

Figure 11.3 - Beam Cross Section

11.3 - The Simplified ACI Code Method

The ACI code simplifies the calculation of flexural strength by permitting the direct use of approximate equations for f_{ps} , the “ultimate” stress in the prestressed steel at nominal strength, and the assumption that the ultimate stress in the unprestressed steel f_s is f_y , the yield stress. Equations for f_{ps} with both bonded and unbonded tendons are

presented in the Code and in Section 11.4(d) (note that the stress-strain method described above cannot directly be used when the tendons are unbonded and have no strain compatibility with the concrete).

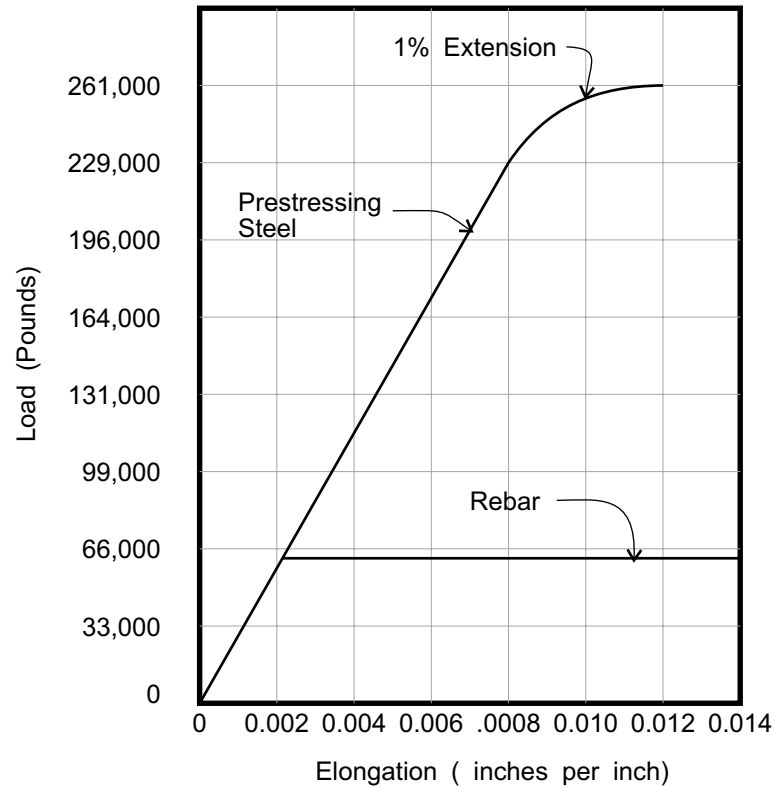

Figure 11.4 - Stress-Strain Diagrams

To insure ductility at nominal strength, and to guarantee that the stress values assumed for f_{ps} and f_s are developed, the code places a limit on the amount of tensile reinforcement allowed in any cross section without compression reinforcement. This is analogous to the limit of $0.75\rho_{bal}$ placed on reinforcing steel in non-prestressed members. In prestressed concrete the limit is expressed in terms of a reinforcing index, ω , defined as:

$$\omega = \frac{A_{ps}f_{ps} + A_s f_y - A'_s f_y}{B'd_p f'_c} \quad \text{(Eqn. 11-1)}$$

The code limits ω to a maximum value of $0.36\beta_1$ with no inelastic moment redistribution. If moments are redistributed inelastically the maximum ω is a function of the level of redistribution, but cannot exceed $0.24\beta_1$ (See Chapter 12).

Following are the calculations for nominal strength of the beam section in Figure 11.3 using the ACI Code method.

$$f_{ps} = 270 \left(1 - \frac{0.4 \times 0.918 \times 270}{0.85 \times 12 \times 20 \times 4} \right) = 237 \text{ ksi} \quad \text{(Eqn. 11-13)}$$

$$T_p = 0.918 \times 237 = 217.6 \text{ kips} \quad T_r = 1.27 \times 60 = 76.2 \text{ kips}$$

$$a_c = \frac{217.6 + 76.2}{0.85 \times 4 \times 12} = 7.2''$$

$$a_{cmax} = \frac{0.306 \times 20}{0.85} = 7.2'' \quad \text{OK} \quad \text{(Eqn. 11-3)}$$

Thus M_n by the ACI code method is 414 foot-kips, about 2% less than the 424 foot-kips calculated using the stress-strain method of section 11.2. The reinforcing index ω for this cross-section is 0.306, which is precisely the upper limit for tensile reinforcing without the addition of compression reinforcing. This comparison indicates a conservative, but good agreement between the simplified ACI code method and the more accurate stress-strain method for calculating flexural strength of this cross-section. The largest discrepancies between the ACI method and the stress-strain method occur when ω is at its maximum value, as in this example. For lower ω values discrepancies are generally less than 2%.

11.4- Strength Calculations in PTData+

PTData+ applies the standard ACI strength methods to post-tensioned concrete cross-sections and assumes a rectangular distribution of uniform concrete compression stresses (equal to $0.85f'_c$) at nominal section strength. For each design point along the frame beams **PTData+** determines the area of unstressed tension steel A_s and unstressed compression steel A'_s required to develop the applied factored moment M_{design} ($=\phi M_n$) at that point. Note that since M_{design} and T_p ($=A_{ps}f_{ps}$) are known at each point, the design of the cross-section for flexural strength involves only the determination of A_s and A'_s .

11.4(a) - The Basic Cross-Section Geometry

The basic “flanged” cross-section used by **PTData+** for resisting concrete compressive stresses is shown cross-hatched in Figure 11.5(a) for downturned beams and in Figure 11.5(b) for upturned beams. Note that downturned beams in **PTData+** may have different slab thicknesses on each side of the web; in this case **PTData+** uses the thinner of the two for the strength cross-section. Also note that if the web width of a

downturned beam varies, **PTData+** uses the minimum web width for B_{bot} in the strength cross-section. Rectangular beams or solid slabs are special cases of the basic flanged cross-section shown in Figure 11.5(a), where $B_{top}=B_{bot}$ and $h=t$.

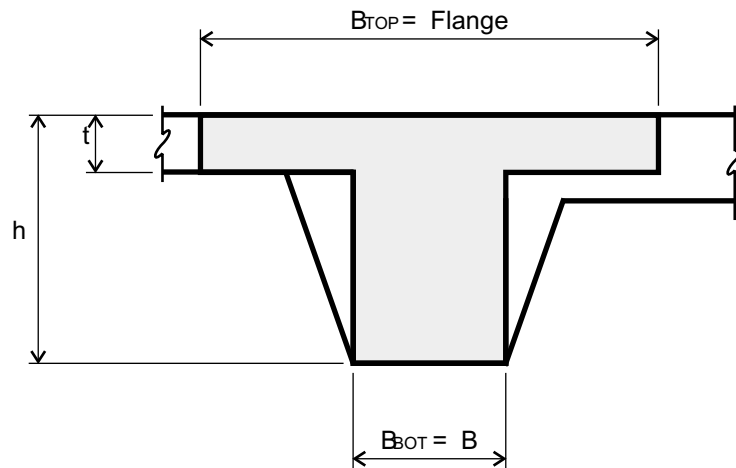

11.5(A) - Downturned

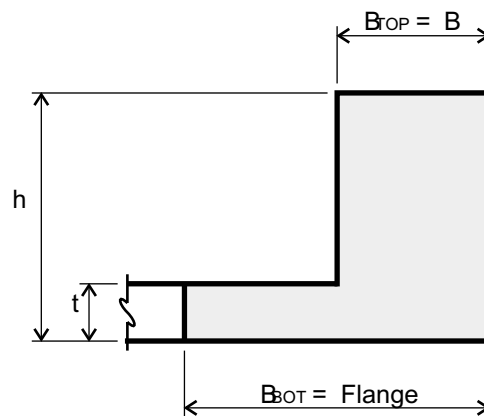

11.5(B) - Uprturned

Figure 11.5 - Basic Strength Cross Sections

For downturned beams in positive bending, Figure 11.7(a) and (b) show how **PTData+** distributes the uniform concrete compressive stress of $0.85f'_c$ on the beam cross-section. If the total concrete compression force C_c is less than $0.85f'_c B_{top}t$ the depth of the compression block is less than the flange thickness t and is a single rectangle with width of B_{top} and depth of a_c as shown in Figure 11.6(a). In this case the resultant concrete compression force C_c is located at a distance $a_c/2$ from the top fi-

ber. If C_c exceeds $0.85f'_c B_{top} t$, however, some compression must be carried in the web as shown in Figure 11.6(b). In this case C_c is located at the centroid of the two rectangles which make up the T-shaped compression zone of Figure 11.6(b).

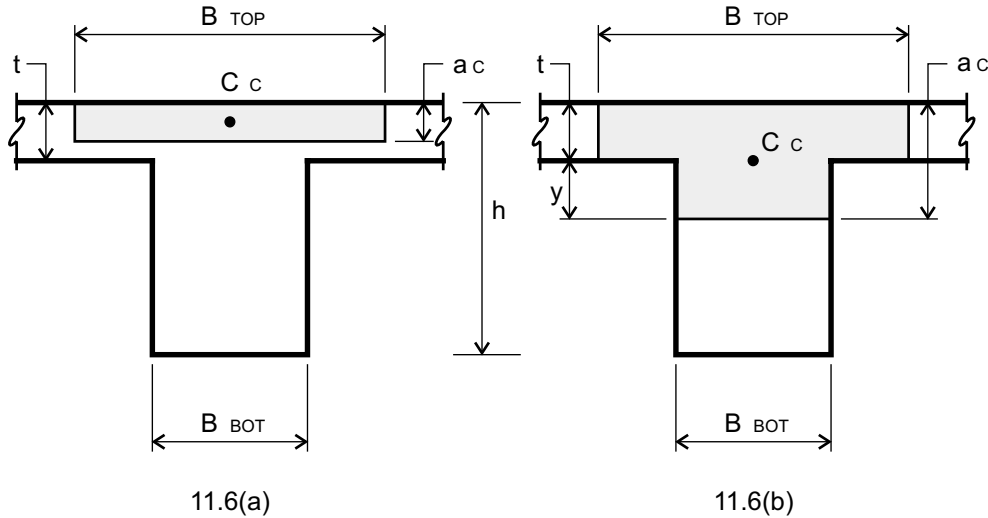

Positive Bending

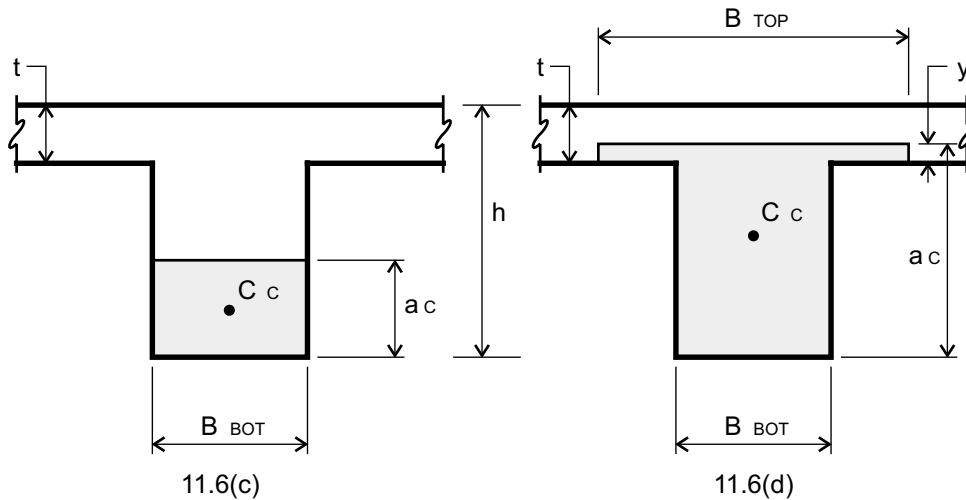

Negative Bending

Figure 11.6 - Concrete Compression Zones

For downturned beams in negative bending, uniform concrete compressive stresses are distributed as in Figures 11.6(c) and (d). If C_c is less than $0.85f'_c B_{bot}(h-t)$ the compression can be developed in the web alone in a single rectangle as shown in Figure 11.6(c). In this case, the resultant compression force C_c is located at $a_c/2$, the centroid of the single compression rectangle. If C_c exceeds $0.85f'_c B_{bot}(h-t)$ the com-

pressive stresses spill into the flange as shown in Figure 11.6(d), and the resultant compression force C_c is located at the centroid of the two rectangles which make up the T-shaped compression zone.

In a similar manner concrete compression diagrams for upturned beams under positive or negative bending are shown in Figure 11.7. Figures 11.7(a) and (b) show upturned beams in positive bending, 11.7(c) and (d) show upturned beams in negative bending.

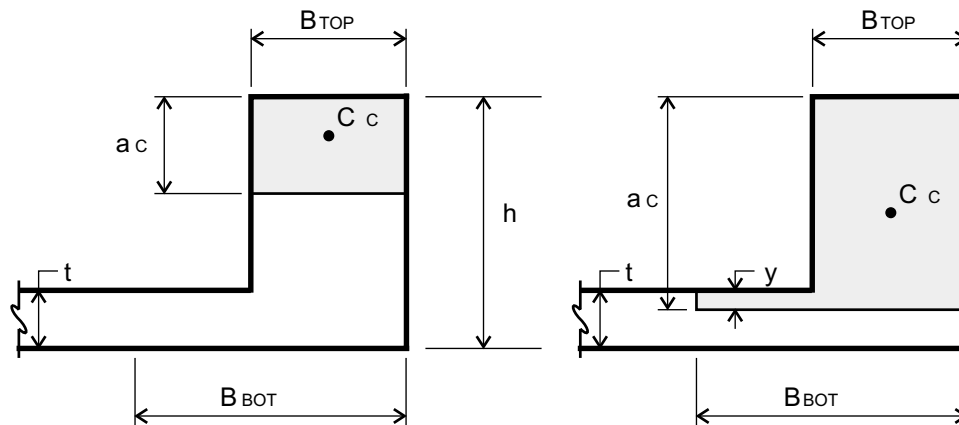

11.7(a)

11.7(b)

Positive Bending

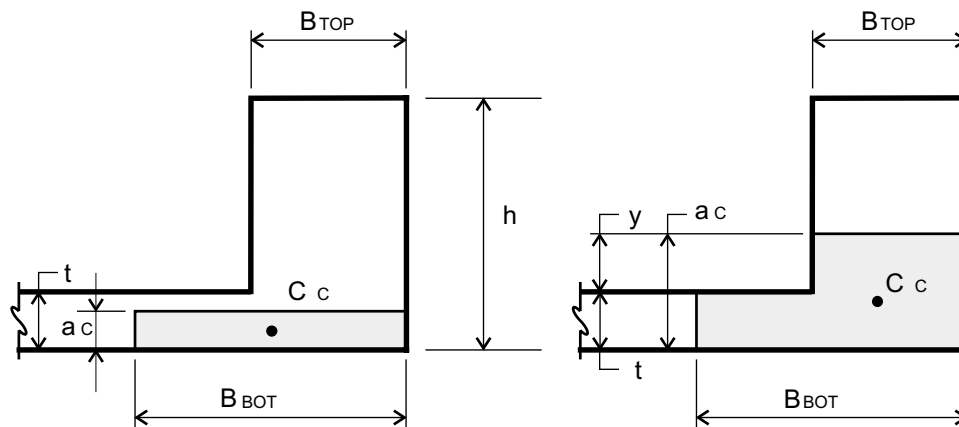

11.7(c)

11.7(d)

Negative Bending

Figure 11.7 - Concrete Compression Zones

11.4(b) - The Reinforcing Index ω

Equation 11-1 for the reinforcing index ω can be written as follows:

$$\omega = \frac{T_p + T_s - C_s}{Bd_p f'_c} \quad \text{(Eqn. 11-2)}$$

For horizontal equilibrium, $T_p + T_s = C_c + C_s$. Solving for C_c :

$$C_c = T_p + T_s - C_s$$

which is the numerator of Eqn. 11-2. C_c is the portion of the total compressive force C which is resisted only by the concrete. The balance of the compressive force C , if any, is the portion resisted by unstressed compression steel, $C_s (=A'_s f_y)$. If the concrete compression stress block is a single rectangle, C_c is:

$$C_c = 0.85 f'_c B a_c$$

Equation 11-2 can therefore be written:

$$\omega = \frac{C_c}{Bd_p f'_c} = \frac{0.85 f'_c B a_c}{Bd_p f'_c} = \frac{0.85 a_c}{d_p} \quad \text{(Eqn. 11-3)}$$

Since d_p is constant for any given design section, Eqn. 11-3 shows that the reinforcing index ω for rectangular cross sections can thus be determined knowing only the depth of the compression block a_c .

For flanged cross-sections, the ACI code specifies that the reinforcing index ω shall be based on the tensile force required to develop the web only. In **PTData+** the web of the basic cross section (Figure 11.5) is always rectangular. Therefore, Eqn. 11-3 may be used for all **PTData+** cross sections. With dimensions defined as in Figures 11.6 and 11.7 the reinforcing index for all **PTData+** cross sections can be calculated by the simple equation:

$$\omega = \frac{0.85 a_c}{d_p} \quad \text{(Eqn. 11-4)}$$

Following are sample calculations for the reinforcing index ω for various downturned **PTData+** cross-sections. These calculations refer to Figures 11.8 through 11.13. Figures 11.8 through 11.10 are for positive moment. For Figure 11.8 :

$$a_c = \frac{386 + 180}{3.4 \times 48} = 3.47''$$

$$\omega = \frac{0.85 \times 3.47}{26} = 0.113$$

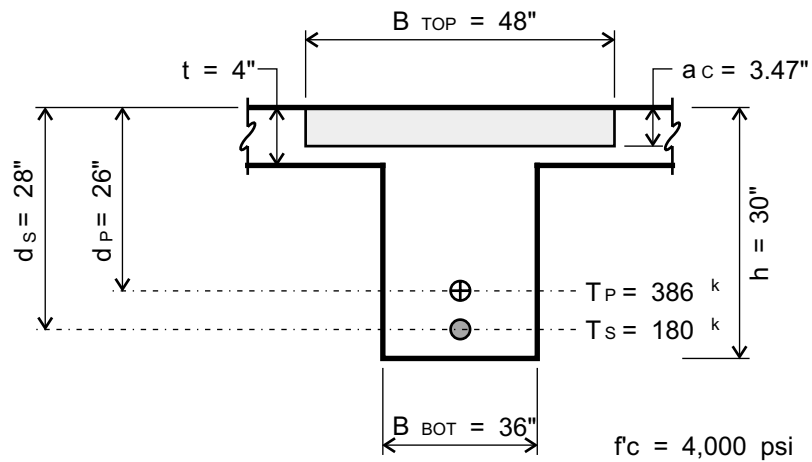

Figure 11.8 - ω Calculation - Positive Bending

For Figure 11.9:

$$T = 780 \text{ kips}$$

$$C_{cf} = 0.85 \times 48 \times 4 \times 4 = 652.8 \text{ kips}$$

$$\Delta F = 780 - 652.8 = 127.2 \text{ kips}$$

$$y = \frac{127.2}{0.85 \times 4 \times 36} = 1.04''$$

$$a_c = 4 + 1.04 = 5.04''$$

$$\omega = \frac{0.85 \times 5.04}{26} = 0.165$$

For Figure 11.10:

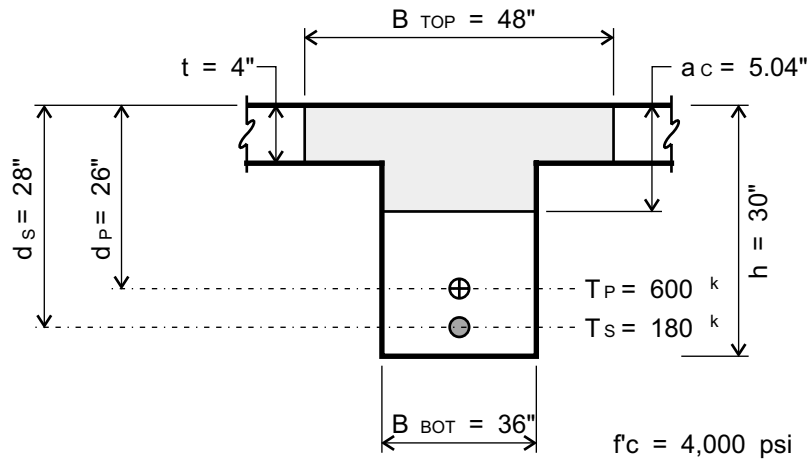

Figure 11.9 - ω Calculations - Positive Bending

For Figure 11.11:

$$C_c = 700 + 250 - 200 = 750 \text{ kips}$$

$$C_{cf} = 0.85 \times 48 \times 4 \times 4 = 652.8 \text{ kips}$$

$$\Delta F = 750 - 652.8 = 97.2 \text{ kips}$$

$$y = \frac{97.2}{3.4 \times 36} = 0.79''$$

$$a_c = 4 + 0.79 = 4.79''$$

$$\omega = \frac{0.85 \times 4.79}{26} = 0.156$$

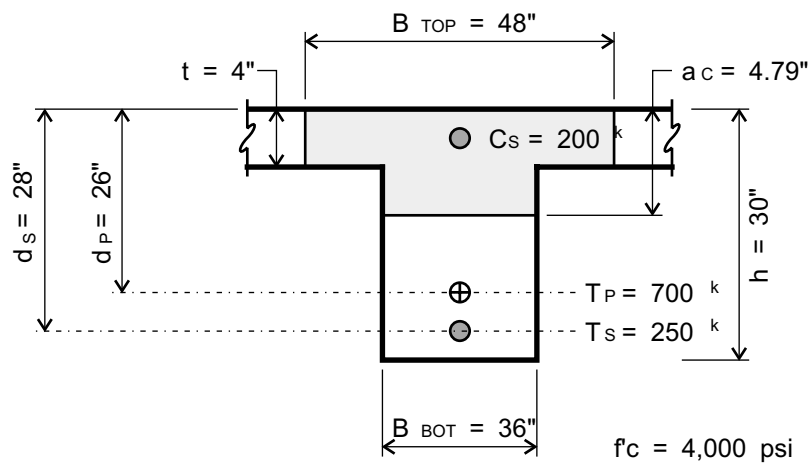

Figure 11.10 - ω Calculation - Positive Bending

For Figure 11.12:

$$T = 600 \text{ kips}$$

$$a_c = \frac{600}{3.4 \times 24} = 7.35''$$

$$\omega = \frac{0.85 \times 7.35}{13} = 0.481$$

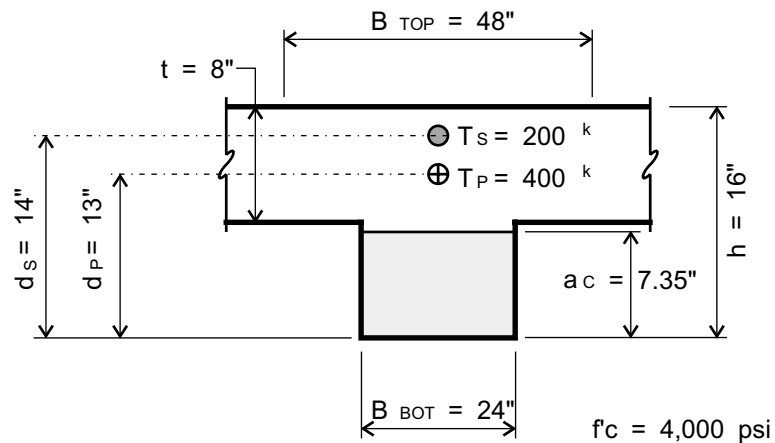

Figure 11.11 - ω Calculation - Negative Bending

For Figure 11.13:

$$T = 800 \text{ kips}$$

$$C_{cw} = 0.85 \times 4 \times 24 \times 8 = 652.8 \text{ kips}$$

$$\Delta F = 800 - 652.8 = 147.2 \text{ kips}$$

$$y = \frac{147.2}{3.4 \times 48} = 0.9''$$

$$a_c = 8 + 0.9 = 8.9''$$

$$\omega = \frac{0.85 \times 8.9}{13} = 0.582$$

Calculations for upturned beams are similar.

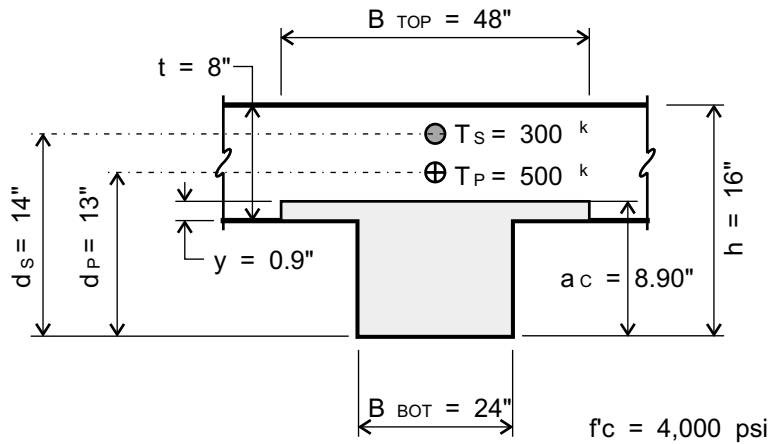

Figure 11.12 - ω Calculation - Negative Bending

$$T = 566 \text{ kips}$$

$$C_c = 566 - 200 = 366 \text{ kips}$$

$$a_c = \frac{366}{3.4 \times 24} = 4.49''$$

$$\omega = \frac{0.85 \times 4.49}{13} = 0.293$$

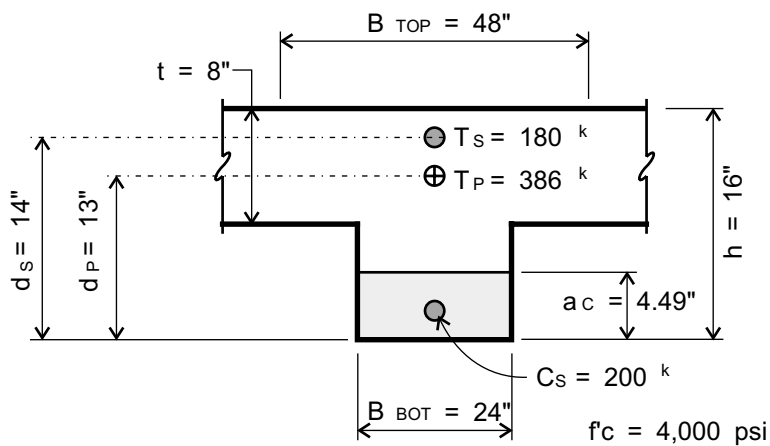

Figure 11.13 - ω Calculation - Negative Bending

11.4(c) - How PTDData+ Calculates A_s and A'_s

PTData+ first calculates M_{cmax} , the maximum moment permissible at the design section without compression steel A'_s . If the applied ultimate moment M_{design} at the design section exceeds M_{cmax} , compression reinforcement is required. If M_{design} is less than or equal to M_{cmax} , compression reinforcement is not required. M_{cmax} is thus an important value for each cross-section, since it is the moment which defines the “borderline” for compression reinforcement. Also determined in this first step is the area of unstressed tension steel A_{sI} which is required to develop M_{cmax} . This is done with the method described in Section 11.4(c)1 substituting M_{cmax} for M_{design} and A_{sI} for A_s in Eqn. 11-5.

M_{cmax} is calculated by first determining the depth of the rectangular compression block a_c when w is at its maximum value. From Eqn. 11-4:

$$a_c = \frac{\omega_{max} d_p}{0.85}$$

Knowing a_c with maximum w , the maximum concrete compression force C_{cmax} can be determined. This establishes the maximum tensile force T which is equal to C_{cmax} . If T is less than or equal to T_p , then T is applied only at the level of the prestressing steel and $d=d_p$. If T is greater than T_p , however, the tensile force is applied at both the prestressed steel level and the unstressed reinforcing level (T_p is applied at d_p and $T-T_p$ is applied at d_s .) In this case d is measured to the resultant location of the tensile reinforcement. Note that the calculations for M_{cmax} use d (depth to the *resultant* location of the tensile force) and T (the *total* tensile force in both prestressed and unprestressed reinforcement), values which are easily determined once C_{cmax} is known. Following are the M_{cmax} values for all possible **PTData+** cross-sections (refer to Figures 11.14 through 11.21):

Figure 11.14, downturned, positive bending, compression in flange:

$$M_{cmax} = \phi f'_c B_{top} \omega_{max} d_p \left(d - \frac{\omega_{max} d_p}{1.7} \right)$$

Figure 11.15, downturned, positive bending, compression in web and flange:

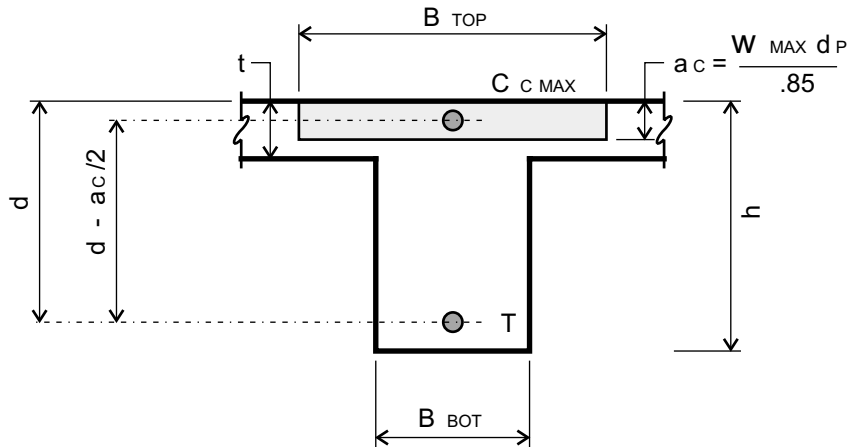

Figure 11.14 - Mcmax Calculation - Positive Bending

$$M_{cmax} = 0.85\phi f'_c \left[t(B_{top} - B_{bot}) \left(d - \frac{t}{2} \right) + B_{bot} \frac{\omega_{max} d_p}{0.85} \left(d - \frac{\omega_{max} d_p}{1.7} \right) \right]$$

Figure 11.16, downturned, negative bending, compression in web:

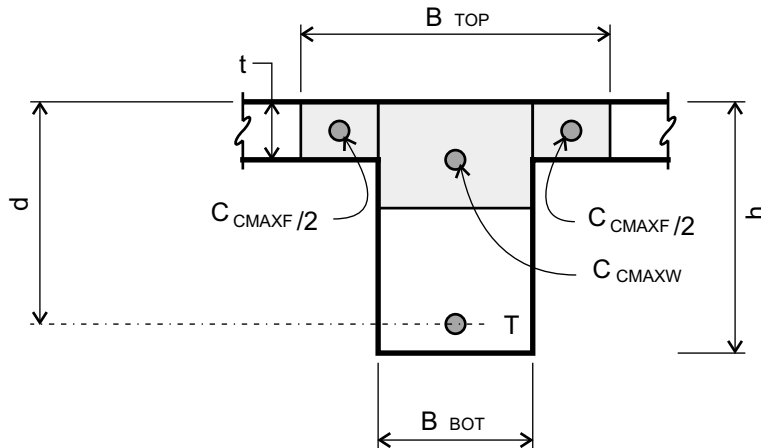

Figure 11.15 - Mcmax Calculation - Positive Bending

$$M_{cmax} = \phi B_{bot} \omega_{max} d_p f'_c \left(d - \frac{\omega_{max} d_p}{1.7} \right)$$

Figure 11.17, downturned, negative bending, compression in web and flange:

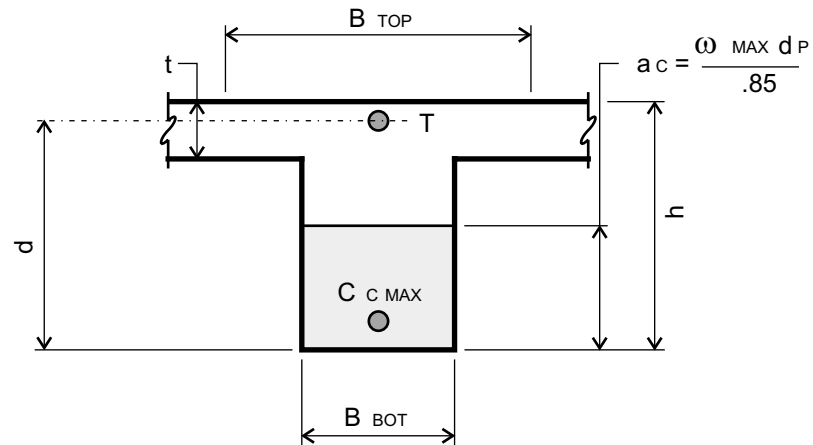

Figure 11.16 - M_{cmax} Calculation - Negative Bending

$$M_{cmax} = 0.85\phi f'_c \left[(B_{top} - B_{bot}) \left(\frac{\omega_{max} d_p}{0.85} - h + t \right) \left(d - 0.5 \left(h - t + \frac{\omega_{max} d_p}{1.7} \right) \right) + \frac{B_{bot} \omega_{max} d_p}{0.85} \left(d - \frac{\omega_{max} d_p}{1.7} \right) \right]$$

Figure 11.18, upturned, positive bending, compression in web:

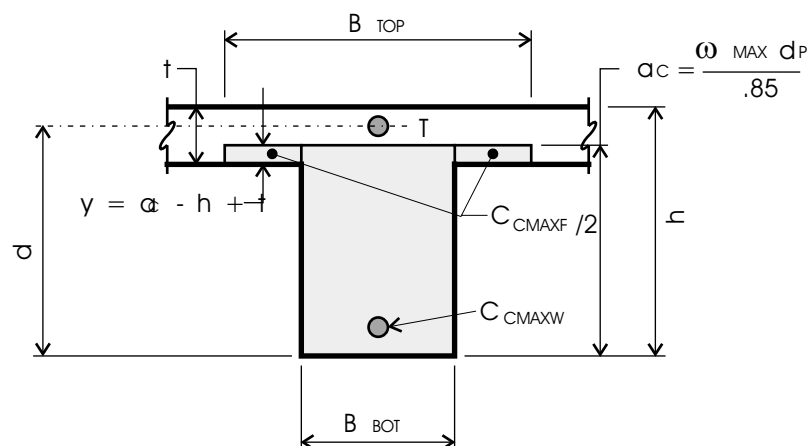

Figure 11.17 - M_{cmax} Calculation - Negative Bending

$$M_{cmax} = \phi B_{top} \omega_{max} d_p f'_c \left(d - \frac{\omega_{max} d_p}{1.7} \right)$$

Figure 11.19, upturned, positive bending, compression in web and flange:

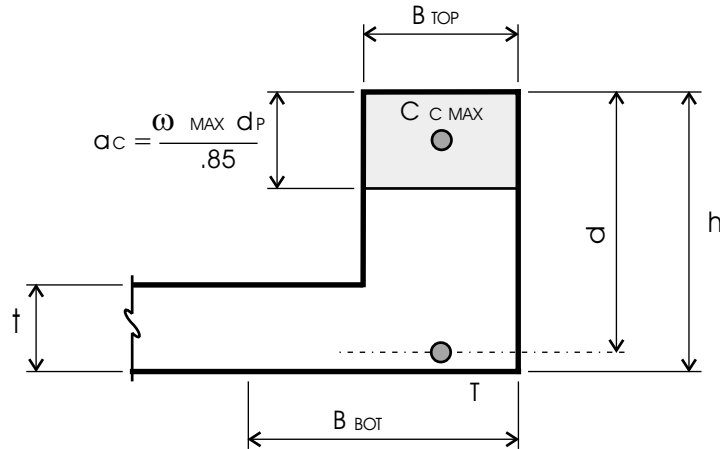

Figure 11.18 - M_{cmax} Calculation - Positive Bending

$$M_{cmax} = 0.85\phi f'_c \left[(B_{bot} - B_{top}) \left(\frac{\omega_{max} d_p}{0.85} - h + t \right) \left(d - 0.5 \left(h - t + \frac{\omega_{max} d_p}{1.7} \right) \right) + \frac{B_{top} \omega_{max} d_p}{0.85} \left(d - \frac{\omega_{max} d_p}{1.7} \right) \right]$$

Figure 11.20, upturned, negative bending, compression in flange:

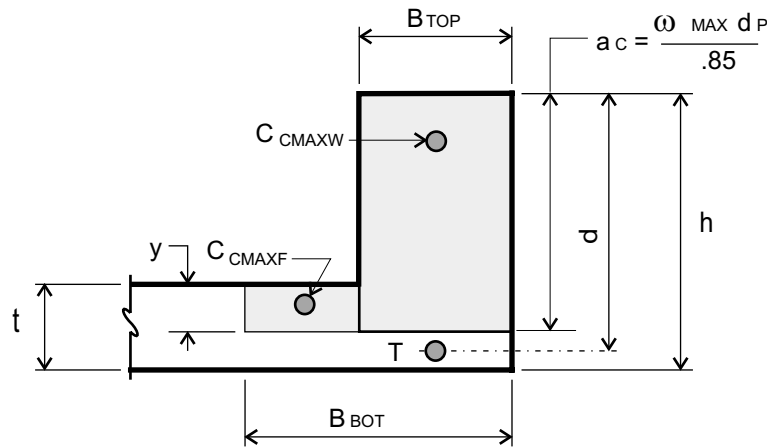

Figure 11.19 - M_{cmax} Calculation - Positive Bending

$$M_{cmax} = \phi B_{bot} \omega_{max} d_p f'_c \left(d - \frac{\omega_{max} d_p}{1.7} \right)$$

Figure 11.21, upturned, negative bending, compression in web and flange:

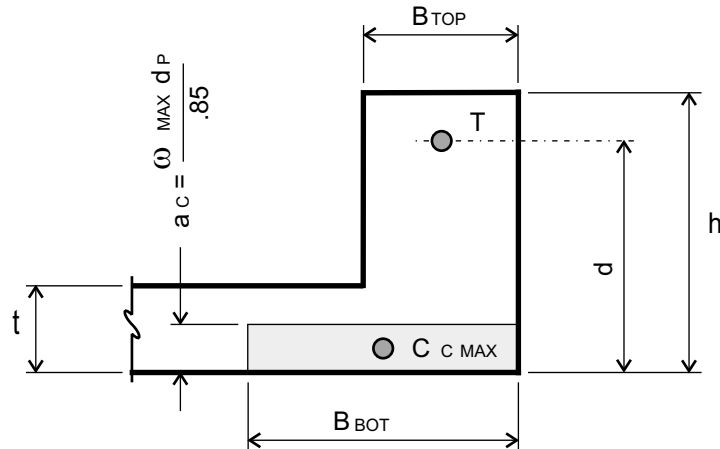

Figure 11.20 - M_{cmax} Calculation - Negative Bending

$$M_{cmax} = 0.85 \phi f'_c \left[t (B_{bot} - B_{top}) \left(d - \frac{t}{2} \right) + B_{top} \frac{\omega_{max} d_p}{0.85} \left(d - \frac{\omega_{max} d_p}{1.7} \right) \right]$$

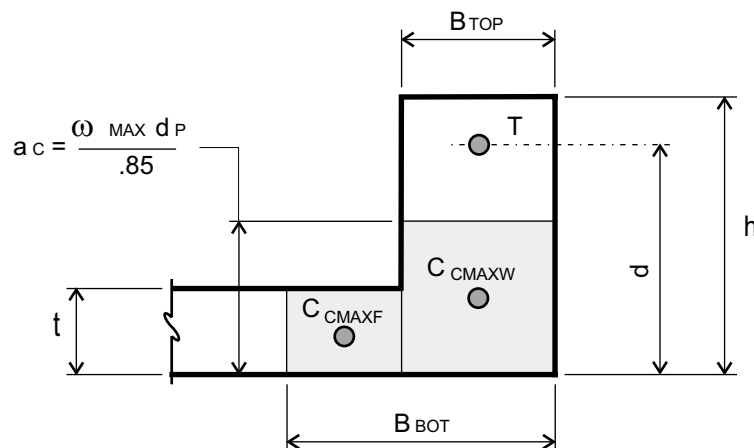

Figure 11.21 - M_{cmax} Calculation - Negative Bending

11.4(c)1 - Sections Requiring Tension Steel Only

If no compression steel is required ($M_{design} \leq M_{cmax}$) **PTData+** determines A_s such that:

$$\phi [T_p(d_p - y_c) + A_s f_y (d_s - y_c)] = M_{design} \quad (\text{Eqn. 11-5})$$

as shown in Figure 11.22 where y_c is the resultant location of the total compression force C , which is resisted completely by concrete compression. For single-rectangle compression blocks, **PTData+** solves Eqn. 11-5 for A_s directly:

$$A_s = \frac{1.7f'_c B' d_s - 2T_p - \sqrt{(1.7f'_c B' d_s - 2T_p)^2 - 4(22.67f'_c B' M_{design} - 1.7T_p f'_c B' d_p + T_p^2)}}{2f_y}$$

Figure 11.22 - Capacity with Tension Steel Only

For T-shaped compression blocks (2 rectangles) A_s is determined by iteration.

11.4(c)2 - Sections Requiring Tension and Compression Steel

If compression steel is required ($M_{design} > M_{cmax}$) **PTData+** supplies the required flexural capacity above M_{cmax} ($M_{design} - M_{cmax}$) by a “ $T-C$ ” couple formed by the tension and compression steel. The calculation for A_s and A'_s depends on whether C_{cmax} (the concrete compression force associated with M_{cmax}) is larger or smaller than T_p . In Figure 11.23(a), C_{cmax} is less than or equal to T_p and therefore part of the incremental tensile force T ($T_p - C_{cmax}$) is located at the level of the prestressed reinforcement, with the balance of T ($A_s f_y$) located at the level of the unstressed tensile steel. A_s and A'_s are determined as follows:

$$A_s = \frac{\frac{M_{design} - M_{cmax}}{\phi} - (T_p - C_{cmax})(d_p - d'_s)}{f_y (d_s - d'_s)} \geq 0 \quad (\text{Eqn. 11-6})$$

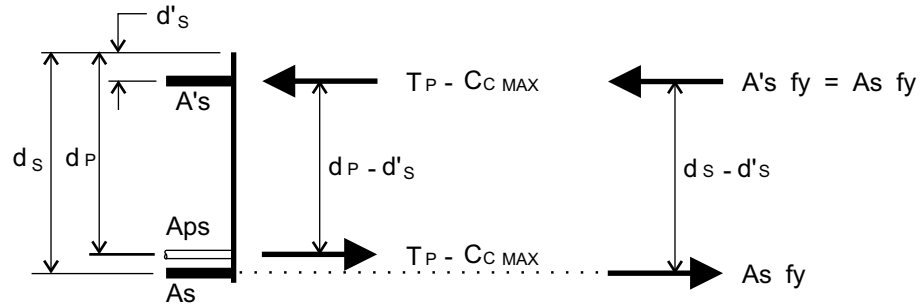

11.23 (a) - $C_{cMAX} \leq T_p$

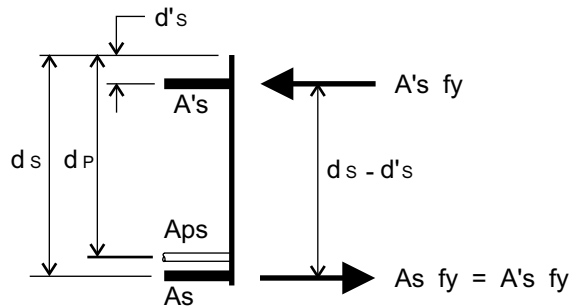

11.23 (b) - $C_{cMAX} \geq T_p$

Figure 11.23 - Capacity in Excess of M_{cmax}

$$A'_s = \frac{T_p - C_{cmax}}{f_y} + A_s \quad (\text{Eqn. 11-7})$$

In Figure 11.23(b), C_{cmax} is greater than T_p and the entire incremental tensile force is located at the level of the unstressed tensile steel. In this case A'_s and A_s are:

$$A'_s = \frac{M_{design} - M_{cmax}}{\phi f_y (d_s - d'_s)} \quad (\text{Eqn. 11-8})$$

$$A_s = A_{s1} + A'_s \quad (\text{Eqn. 11-9})$$

Note that A_{s1} is the unstressed tension steel required in the M_{cmax} calculation (see Section 11.4(c)). The total flexural capacity of a section with tension and compression steel can thus be determined as follows, with reference to Figure 11.24, taking moments about C_{cmax} :

$$\phi [C_r (y_c - d'_s) + T_p (d_p - y_c) + T_r (d_s - y_c)] \geq M_{design} \quad (\text{Eqn. 11-10})$$

where y_c is the resultant location of the maximum concrete compression force C_{cmax} , determined with $w=w_{max}$ in the calculation for M_{cmax} (see Figures 11.14 through 11.21).

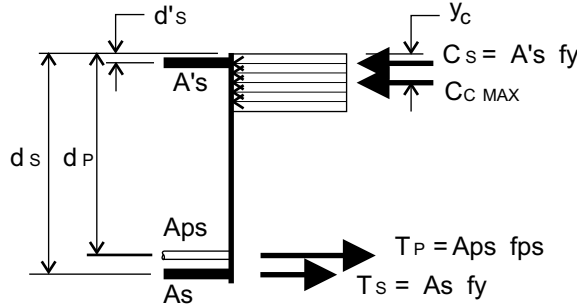

Figure 11.24 - Capacity with Tension and Compression Steel

11.4(d) - The Ultimate Tendon Stress fps

The ultimate flexural capacity of a cross-section is directly related to f_{ps} , the tendon stress at nominal strength M_n . f_{ps} is the maximum tensile stress which can be developed in the tendons before reaching a concrete compressive strain ϵ_c of 0.003. Code limitations on ω *guarantee* that f_{ps} is developed *before* $\epsilon_c = 0.003$ is reached. Code equations for f_{ps} are different for unbonded and bonded tendons.

11.4(d)1 - Unbonded Tendons

For unbonded tendons **PTData+** uses the following equations for f_{ps} , the tendon stress at nominal strength, at each design point:

For members with $L/h \leq 35$:

$$f_{ps} = f_{se} + 10 \text{ ksi} + \frac{f'_c B' d_p}{100 A_{ps}} \quad \text{(Eqn. 11-11)}$$

where f_{ps} cannot exceed either f_y or $(f_{se} + 60 \text{ ksi})$.

For members with $L/h > 35$:

$$f_{ps} = f_{se} + 10 \text{ ksi} + \frac{f'_c B' d_p}{300 A_{ps}} \quad \text{(Eqn. 11-12)}$$

where f_{ps} cannot exceed either f_y or $(f_{se} + 30 \text{ ksi})$.

In the constant prestress force mode, **PTData+** f_{se} is a user-controlled variable which appears in the PTDATA.CNF file (see **APPLICATION** Section 1.3). Default (as-shipped) values for f_{se} are 173 ksi (26.5 kips per 1/2"-270 ksi strand) for low relaxation prestressing steel and 162 ksi (24.8 kips per 1/2"-270 ksi strand) for stress-relieved prestressing steel. The cross-sectional area of prestressed steel A_{ps} is assumed to be F/f_{se} in the constant force method.

In the variable prestress force mode, **PTData+** calculates the precise value of f_{se} at each design point based upon the actual friction and longterm losses in the tendon. A jacking stress of 216 ksi ($0.8f_{pu}$) is assumed. In the variable prestress force mode, the actual area of prestressed steel A_{ps} is an input value.

11.4(d)2 - Bonded Tendons

PTData+ uses the following equation to calculate f_{ps} in bonded prestressing tendons at each design point:

$$f_{ps} = f_{pu} \left[1 - \frac{\gamma_p}{\beta_1} \left(\frac{A_{ps} f_{pu}}{B' d_p f'_c} \right) \right] \quad \text{(Eqn. 11-13)}$$

where $\gamma_p = 0.40$ for stress-relieved prestressing steel and 0.28 for low relaxation steel. An examination of ACI 318-89 Equation 18-3 shows that in Eqn. 11-13 **PTData+** assumes $\omega = \omega'$ ($A_s = A'_s$), for bonded members. This is done for two reasons:

- A_s and A'_s are normally not known at the point in the design when f_{ps} is needed. Thus an extensive iterative procedure would be required to include A_s and A'_s in the calculations for f_{ps} .
- f_{ps} is not sensitive to A_s / A'_s . For typically proportioned post-tensioned beams, a change of 100% in the value of A_s / A'_s results in about a 4% change in f_{ps} .

Note that Eqn. 11-13 is independent of f_{se} and therefore applies as shown in both the constant force and the variable force methods.

This page intentionally left blank

Chapter Twelve

Inelastic Moment Redistribution

12.1 - Inelastic Theory in Continuous Beams

Inelastic behavior in prestressed concrete is based upon an assumed bilinear moment-curvature relationship shown in Figure 12.1. The cross-section is assumed to

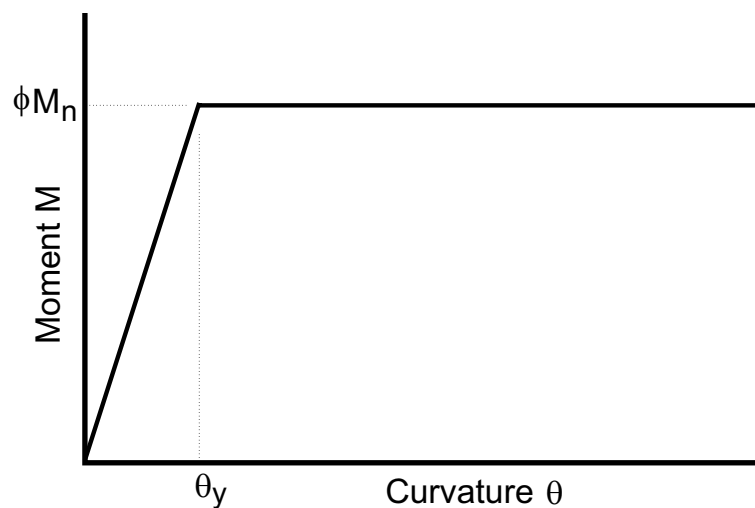

Figure 12.1 - Idealized Moment-Curvature Relationship

respond elastically up to an applied moment of ϕM_n at which point the section becomes a “plastic hinge”, i.e., additional curvature occurs with no additional moment.

Figure 12.2 shows a moment diagram for an interior span L of a multispan continuous beam. The beam has constant positive and negative capacities ϕM_n of 4 “units”. In the elastic range the negative moment at each end of the beam is $wL^2/12$ and the positive moment at midspan is $wL^2/24$. Curve 1 is an elastic moment diagram in which the negative moment has just reached the “yield” moment of 4. Under this load the positive moment is 2. The load which produces this moment diagram (Curve 1) is:

$$w_1 = \frac{12 \times 4}{L^2} = \frac{48}{L^2}$$

As the load increases beyond w_1 the ends of the beam act as hinges undergoing rotation with no increase in moment (the moment stays constant at 4 units). The beam is stable and can carry additional load as a simple-span determinate beam with pinned ends and a constant end moment. This post-yielding rotation is an inelastic behavior, and the amount of rotation possible before failure (crushing of the concrete or tensile rupture of the steel) is a measure of the ductility of the section. At some load w_2 the midspan yield moment of 4 units will be reached and the inelastic moment diagram of Curve 2 will be produced. At this point the beam has now developed three “hinges” and becomes a “collapse mechanism”, incapable of additional load. The load w_2 which produces the moment diagram of Curve 2 can be calculated as follows:

$$\frac{w_2 L^2}{8} = \phi M_n^+ + \phi M_n^- = 8$$

$$w_2 = \frac{64}{L^2}$$

w_2 is called the “limit load”, the maximum load possible in this span by inelastic theory. The attainment of the limit load depends on the capability of the support sections to undergo the inelastic rotations required between loads w_1 and w_2 . It is of interest to calculate the moment diagram which would be produced if the beam responded elastically to the limit load w_2 . The negative moment at each end of the beam would be:

$$M^- = \left(\frac{64}{L^2}\right) \frac{L^2}{12} = \frac{64}{12} = 5.33$$

The positive elastic moment would be:

$$M^+ = \left(\frac{64}{L^2}\right) \frac{L^2}{24} = 2.67$$

Curve 3 is the elastic moment diagram which would be produced by the limit load w_2 . Wherever the elastic Curve 3 exceeds the yield capacity ϕM_n , inelastic behavior is required. The areas where inelastic behavior is required at each end of the beam are shown shaded in Figure 12.2. The ratio between the elastic moment and the yield moment at any point is a measure of the amount of inelastic behavior, or “redistribution”, required at that point to develop the limit load w_2 . More specifically, the

amount of redistribution required is defined as $100(1-\phi M_n/M_e)$ where M_e is the elastic moment at the point of interest. In the example of Figure 12.2 the amount of redistribution required at the ends of the beam to develop the load w_2 is:

$$\%R = 100\left(1 - \frac{4}{5.33}\right) = 24.9\%$$

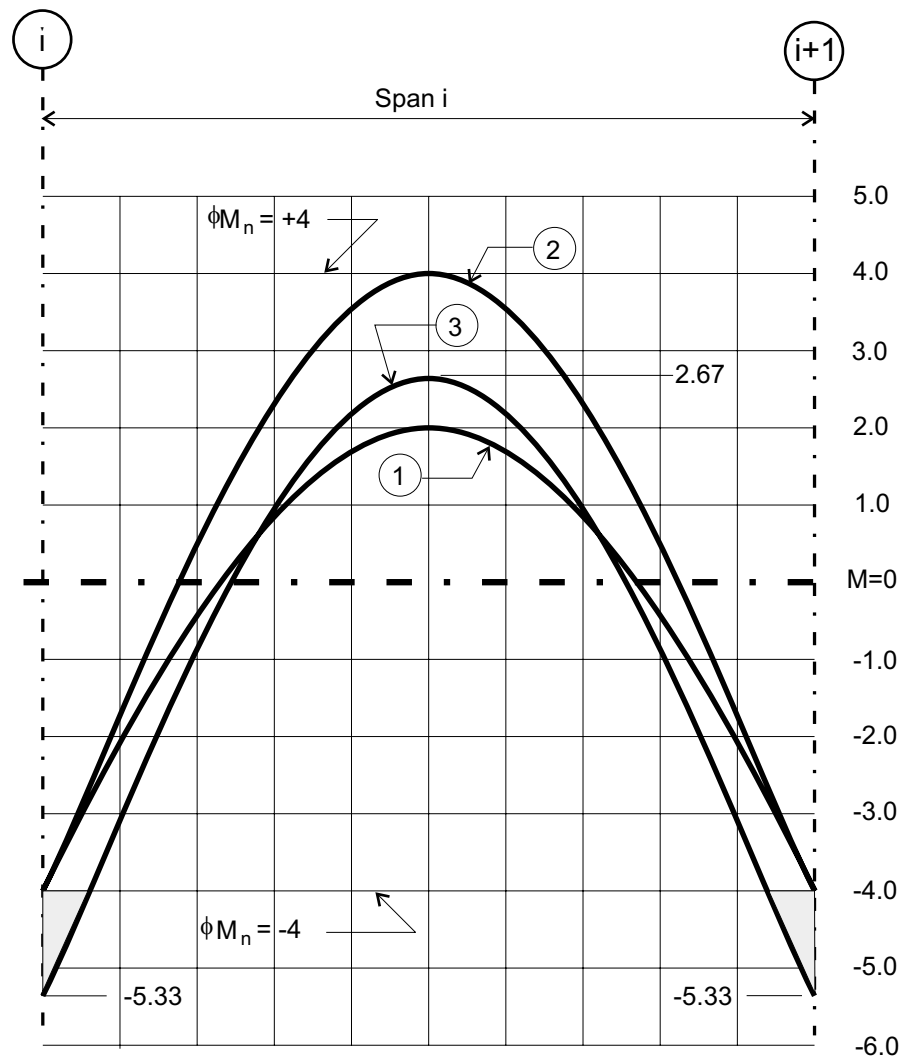

Figure 12.2 - Moment Redistribution

It is also possible for yielding to occur first at midspan. Figure 12.3 shows such a case, where the elastic moment diagrams are identical to those in Figure 12.2, but the capacities at supports and midspan are 3 and 1 respectively. A load of w_1 produces Curve 1, the elastic moment diagram in which the positive moment has just reached $\phi M_n = 1$ at midspan. The magnitude of w_1 is:

$$w_1 = \frac{12 \times 2}{L^2} = \frac{24}{L^2}$$

A hinge develops in the beam at midspan under this load, and additional load beyond w_1 is carried by the beam in the form of two cantilevers off of the left and right supports. The support moments increase until, at a limit load of w_2 , the supports yield and the inelastic moment diagram is Curve 2 in Figure 12.3. Load w_2 , the limit load, is:

$$\frac{w_2 L^2}{8} = \phi M_n^+ + \phi M_n^- = 4$$

$$w_2 = \frac{32}{L^2}$$

The elastic negative moment which would be produced by w_2 is:

$$M^- = \left(\frac{32}{L^2}\right) \frac{L^2}{12} = 2.67$$

The positive elastic moment under w_2 would be:

$$M^+ = \left(\frac{32}{L^2}\right) \frac{L^2}{24} = 1.33$$

The elastic moment diagram which would be produced by w_2 is shown in Figure 12.3 as Curve 3. The area of the beam requiring inelastic behavior is crosshatched, and the amount of redistribution required at midspan is:

$$\%R = 100 \left(1 - \frac{1}{1.33}\right) = 24.8\%$$

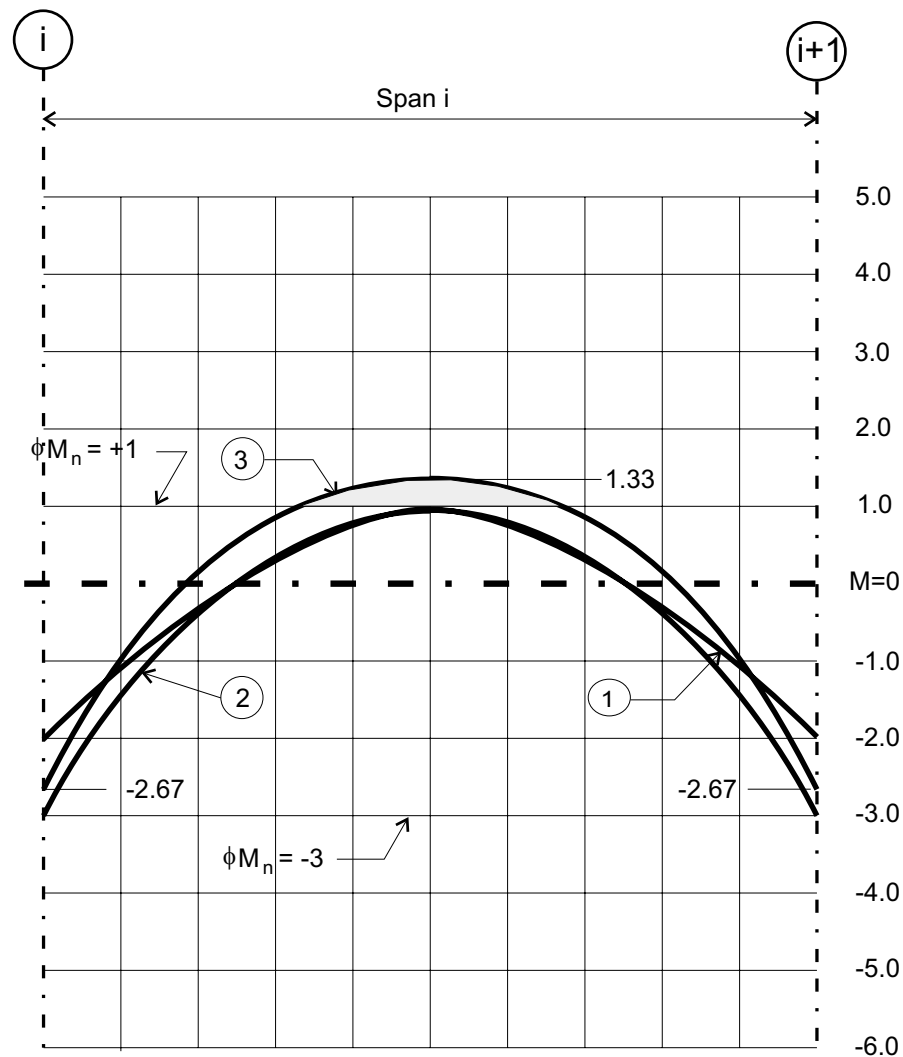

Figure 12.3 - Moment Redistribution

12.2 - Code Redistribution of Ultimate Moments (1.4D+1.7L)

The ACI code permits a limited amount of inelastic moment redistribution in indeterminate post-tensioned frames. **PTData+** applies the redistribution only to factored **gravity moments** (dead and live) and further only to the **maximum** moments at each point (when live load is skipped). **Minimum** moments and moment combinations containing **wind** are **not redistributed** (i.e., they are elastic).

The moment redistribution is accomplished by increasing or decreasing the elastic ultimate **negative moments** in the frame beams by the following percentage:

$$\%R = 20 \left(1 - \frac{\Sigma\omega}{0.36\beta_1} \right) \quad \text{(Eqn. 12-1)}$$

The redistributed negative moment is:

$$M_r = \left(1 - \frac{\%R}{100} \right) (M_{ud} + M_{ul} + M_2)$$

Redistribution is permitted only when $\Sigma\omega$ is less than or equal to $0.24\beta_1$. With $\omega=0.24\beta_1$ in Eqn. 12-1 the lower limit of permissible redistribution can be calculated:

$$\%R = 20 \left(1 - \frac{0.24\beta_1}{0.36\beta_1} \right) = 6.67\%$$

The theoretical upper limit is 20% with $\Sigma\omega=0$, thus if redistribution is used ($\%R$ not equal to zero), $\%R$ can range between 6.67% and 20%. **PTData+** designs the frame beams for three ultimate moment patterns, each with a unique maximum reinforcing index $\Sigma\omega_{max}$:

Pattern	$\%R$	w_{max}
1	0.00	$0.36\beta_1$
2	6.67	$0.24\beta_1$
3	15.00	$0.09\beta_1$

This provides the designer with a wide range of redistribution alternatives from which to select the final beam reinforcement.

12.2(a) - How The Redistribution is Done

The **PTData+** redistribution method will be demonstrated with an example from a continuous beam with skipped live load, using the 15% redistribution case.

Figure 12.4 shows elastic moment diagrams for an interior beam of a multispan frame between grids 2 and 3. Curve 1 is the elastic moment diagram for factored dead and live loads arranged (skipped) to produce the maximum moment at the left end of the

beam. Curve 2 is the elastic moment diagram for maximum moment at the right end of the beam, and Curve 3 is the elastic moment diagram for maximum positive moment in the span. If live load is not skipped, all three of these curves are the same. The secondary moments at the left and right ends of the beam are also shown.

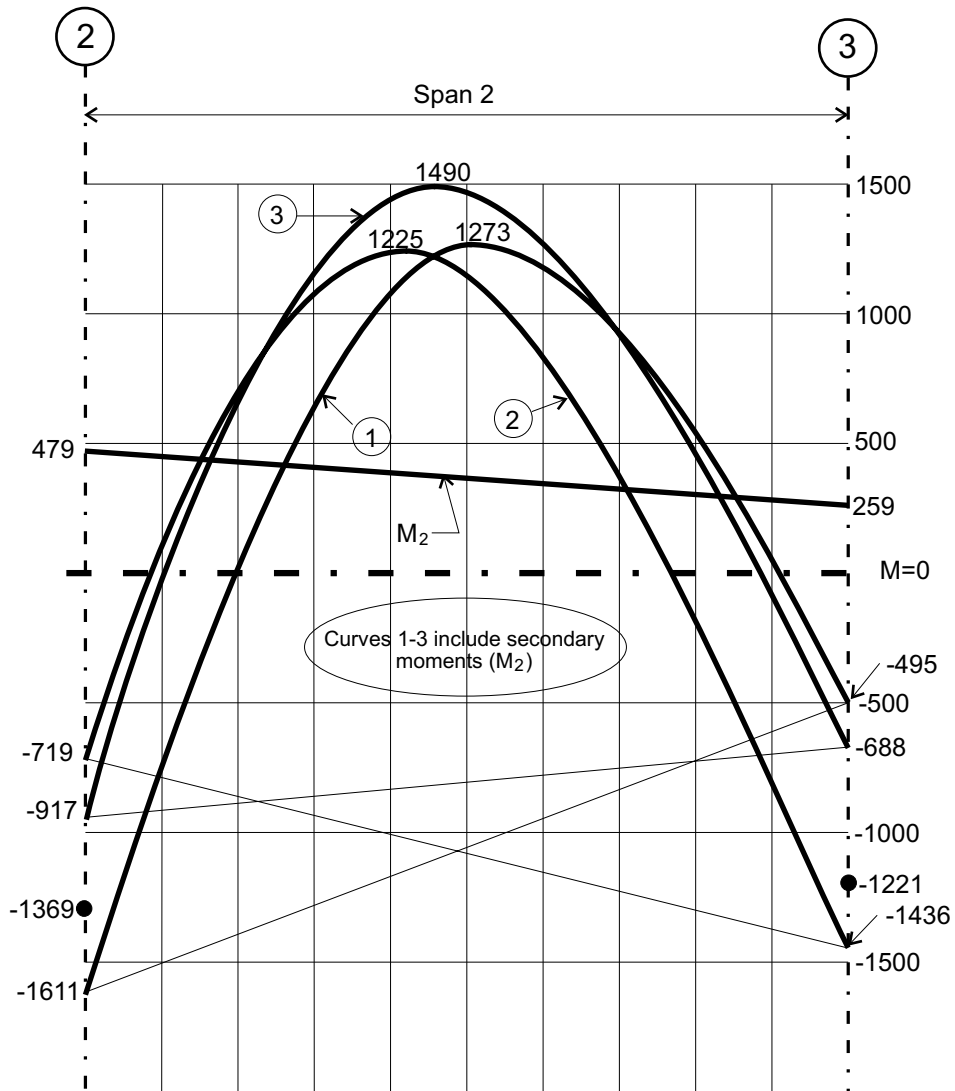

Figure 12.4 - Elastic Moments (1.4DL+1.7LL+ M_2)

First, the design negative moments are determined. They are the maximum moments at the left and right ends of the beam reduced by the appropriate redistribution percentage %R. For %R=15%, the design negative moment at the left end is:

$$M_L = \left(1 - \frac{15}{100}\right)(-1611) = -1369$$

The design negative moment at the right end is:

$$M_R = \left(1 - \frac{15}{100}\right)(-1436) = -1221$$

These two values are shown with the bullet marks in Figure 12.4 at the left and right ends of the beam.

Once the design negative moments are determined, the three elastic moment curves are adjusted so as to minimize the design positive moment. First, Curve 1, for maximum negative moment at the left end, is adjusted such that its negative moments are as close as possible, within the limits of the 15% redistribution, to the negative design moments just established. Referring to Figure 12.5, where the elastic Curve 1 is shown dashed, the left end moment is reduced from -1611 to -1369 foot-kips (Curve 1 was used to establish the design negative moment of -1369 foot-kips at the left end). At the right end, the moment of -495 foot-kips is increased as much as possible up to a maximum of the design negative moment. This minimizes the positive moment in this moment diagram. The right moment can be increased to:

$$\left(1 + \frac{15}{100}\right)(-495) = -569$$

By statics, the maximum positive moment in this diagram is +1357 foot-kips, and the resulting redistributed moment diagram for Curve 1 is shown as the solid line in Figure 12.5.

Curve 2, for maximum negative elastic moment at the right end, is similarly adjusted in Figure 12.6. The elastic right end moment of -1436 foot-kips is reduced to the design negative moment of -1221 foot-kips. The elastic left end moment of -719 foot-kips is increased to:

$$\left(1 + \frac{15}{100}\right)(-719) = -827$$

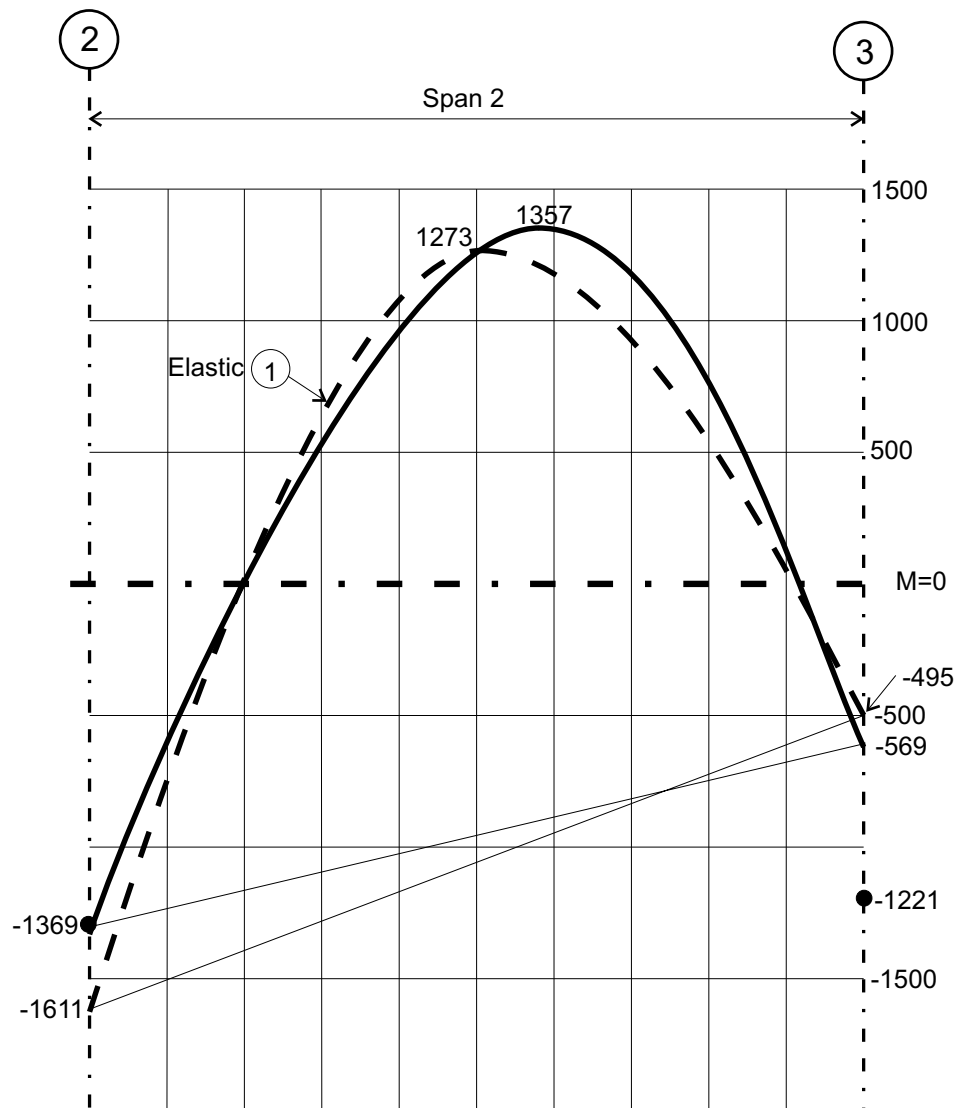

Figure 12.5 - Curve 1 Redistributed 15%

which is less than the design negative moment of -1369 foot-kips. The maximum in-elastic positive moment is established by statics as +1278 foot-kips. The redistributed moment diagram is shown as a solid line in Figure 12.6.

Curve 3, for maximum positive elastic moment, is adjusted in Figure 12.7. In this case both of the end moments can be increased in order to minimize the positive moment. The left end elastic moment of -917 foot-kips is increased to:

$$\left(1 + \frac{15}{100}\right)(-917) = -1055 \text{ foot - kips}$$

and the right end elastic moment of -688 foot-kips is increased to:

$$\left(1 + \frac{15}{100}\right)(-688) = -791 \text{ foot-kips}$$

The maximum positive moment in the inelastic curve is determined by statics as 1370 foot-kips. Note that inelastic behavior is required at midspan in this redistribution, yet the redistribution amount, per the ACI code, is determined *only* by the negative moments where the behavior is elastic.

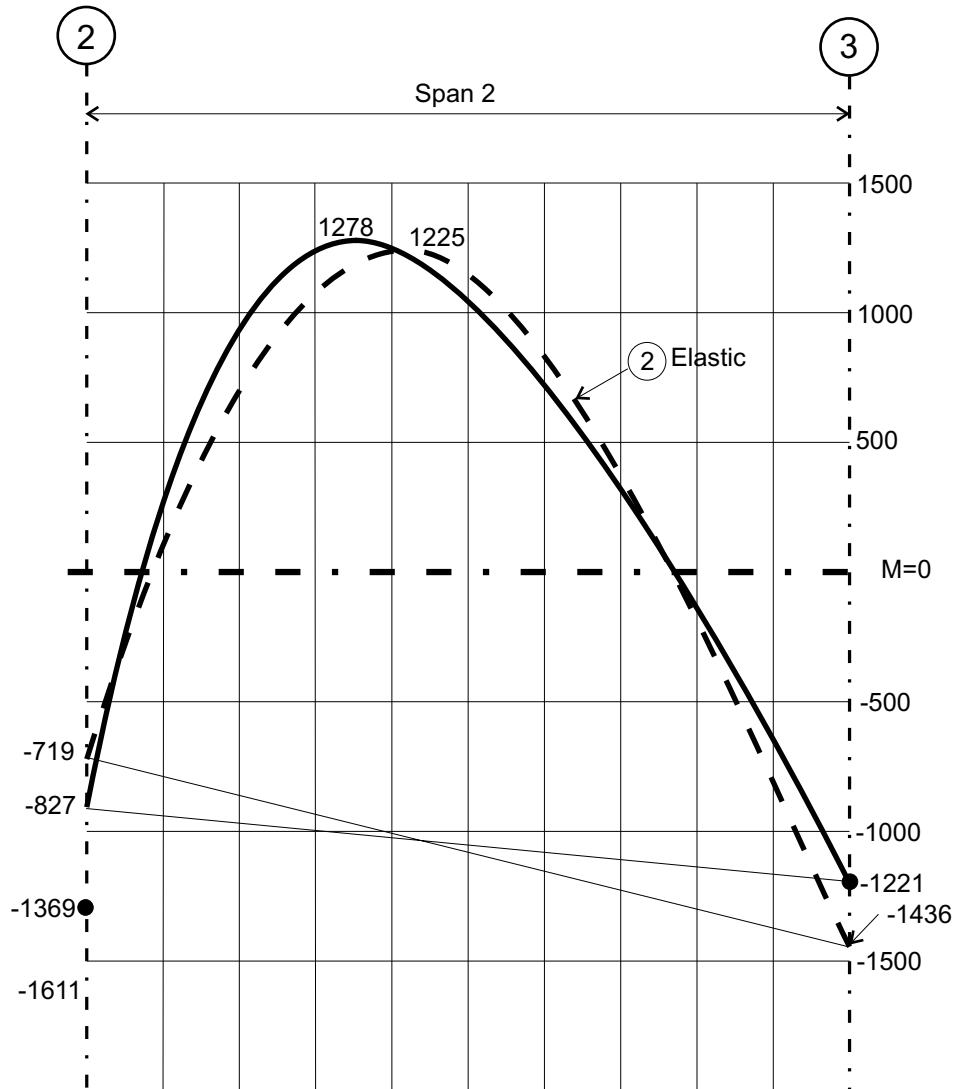

Figure 12.6 - Curve 2 Redistributed 15%

The three redistributed curves are shown together in Figure 12.8, along with the three elastic curves for *minimum* moments at the left end, right end, and midspan. At each design point **PTData+** examines these six curves and selects the most positive and most negative moments for design. The design curves for most positive and most negative moments are shown with dark lines in Figure 12.8. These curves show boundaries of the envelope of moments possible in this span with a 15% moment redistribution.

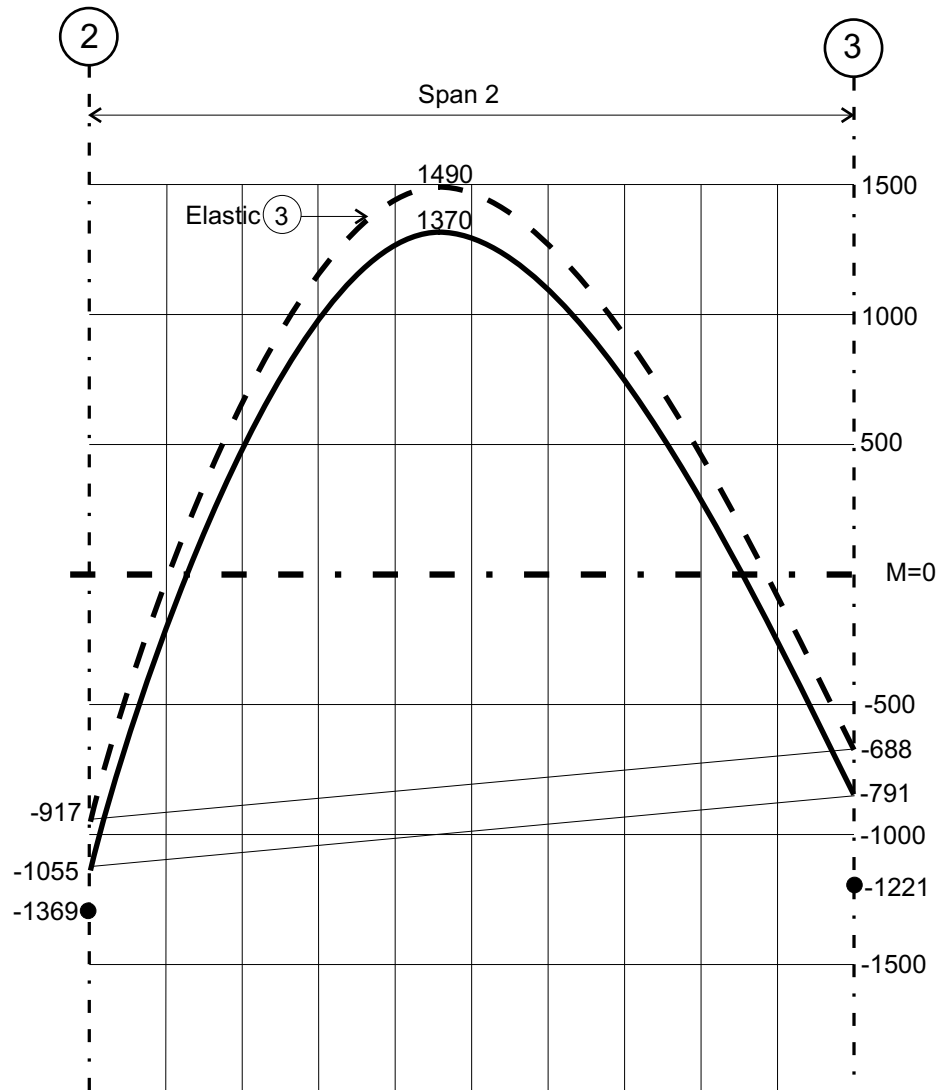

Figure 12.7 - Curve 3 Redistributed 15%

A comparison of Figures 12.4 and 12.8 shows the following for maximum design moments:

	Left End	Midspan	Right End
Elastic	-1611	+1490	-1436
15% Redist.	-1369	+1370	-1221
Change	-15%	-8%	-15%

The redistribution process, in beams with skipped live loads, thus results in a substantial reduction in **both** negative and positive design moments. The reduction in magnitude of these design moments comes with a price, however, for in order to use a 15% redistribution $\Sigma\omega$ must be limited to $0.09\beta_1$ (see Section 12.2). This low value of $\Sigma\omega_{\max}$ can result in substantial amounts of compression reinforcing, which will tend to offset the reduction in tensile steel. The designer must carefully scrutinize the reinforcing required in each of the three redistribution patterns in order to select the one most efficient for a particular frame design.

In selecting the reinforcing steel for any frame design, the designer must select one of the three redistribution patterns and provide at least the steel areas required at each point **for that pattern**. The designer cannot select the most favorable steel areas from the three redistribution patterns at each point, rather the most favorable overall pattern is selected and steel at all points must reflect that required for that *one* pattern.

12.3 - Redistribution of D+L/4 Moments

Redistribution of *D+L/4* moments follows the same procedure as described in Section 12.2 for full factored moments, with several exceptions. In the *D+L/4* case, the beam is treated as if it were non-prestressed (prestressing force is ignored). Redistribution therefore follows ACI code criteria for reinforced, rather than prestressed concrete. The primary difference is in the calculation of %R, as follows:

$$\%R = 20 \left(1 - \frac{\rho}{\rho_b} \right) \quad \text{(Eqn. 12-2)}$$

Redistribution is permitted only when ρ is less than or equal to $0.5\rho_b$. With $\rho = 0.5\rho_b$ in Eqn. 12-2 the lower limit of permissible redistribution can be calculated:

$$\%R = 20 \left(1 - \frac{0.5\rho_b}{\rho_b} \right) = 10\%$$

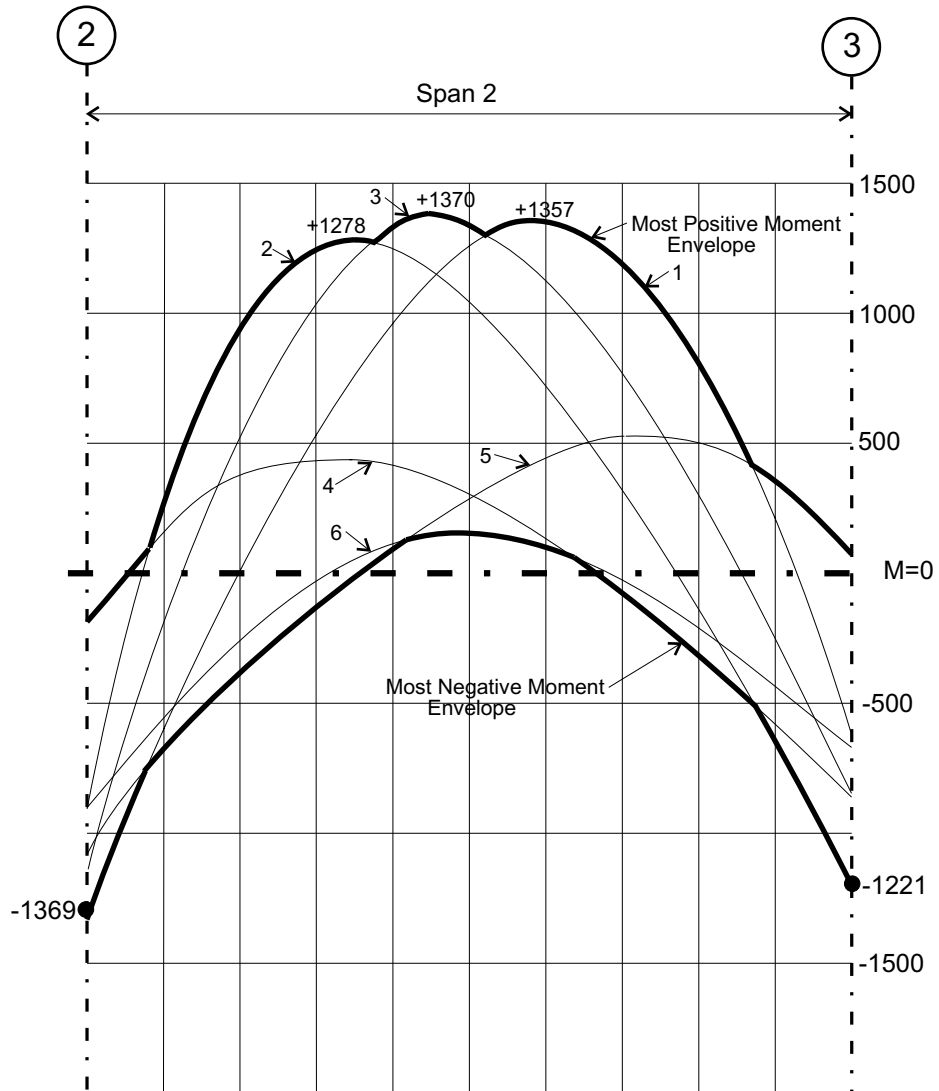

Figure 12.8 - Redistributed Moments

The theoretical upper limit is 20% with $\rho=0$, thus if redistribution is used ($\%R$ not equal to zero), $\%R$ can range between 10% and 20%. **PTData+** determines three design moment patterns for the $D+L/4$ case, each with a unique maximum reinforcing ratio ρ_{max} :

Pattern	$\%R$	ρ_{max}
1	0.0	$0.75\rho_b$
2	10.0	$0.50\rho_b$
3	15.0	$0.25\rho_b$

All other redistribution procedures are identical to those described in Section 12.2(a).

Chapter Thirteen

Deflection

PTData+ calculates the flexural deflection of the frame beams under the action of unfactored service dead and live loads, and the tendon balanced loads. Wind moments are not considered in the deflection analysis.

The bending deflection can be calculated at any point i along the beam using the energy equation:

$$\delta_i = \int_0^L \frac{M(x)m(x)}{E_b I_e(x)} dx$$

where:

δ_i = deflection at any point i .

$M(x)$ = Moment produced by the actual applied loads expressed as a function of x , the distance from the left support centerline.

$m(x)$ = Moment produced by a unit load applied at point i expressed as a function of x .

$I_e(x)$ = Effective moment of inertia of the beam expressed as a function of x .

The integral is evaluated by dividing the span into a finite number of *increments* and using the following summation:

$$\delta_i = \sum_j \frac{M_j m_{ji}}{E_b I_{ej}} \Delta x_j \quad \text{(Eqn. 13-1)}$$

where:

M_j = Moment at increment j produced by actual applied loads.

m_{ji} = Moment at increment j produced by a unit load at i .

Δx_j = Length of increment j .

I_{ej} = Effective moment of inertia of the beam at increment j .

The deflection δ_i is calculated at each of the design points as defined in Chapter 8 (See Figure 8.1). The subscripts i and j both run from 0 to $P+2+2(N-1)$ for spans and 0 to $P+1+2(N-1)$ for cantilevers, where P and N are as defined in Chapter 8. To evaluate Eqn. 13-1, the span between support faces is divided into $P+3+2(N-1)$ increments (one less for cantilevers). Each increment straddles a design point, i.e., the left end of increment j is midway between design points $j-1$ and j ; the right end of increment j is midway between design points j and $j+1$. Figure 13.1 shows the orientation of design points and deflection increments for a span with $P = 4$ and $N = 3$.

The leftmost and rightmost increments (increments 0 and $P+2+2(N-1)$ respectively) are half-increments. Increment 0 extends from design point 0 (the left support face) to a point midway between design point 0 and design point 1. Increment $P+2+2(N-1)$ extends from design point $P+2+2(N-1)$ (the right support face) to a point midway between design points $P+2+2(N-1)$ and $P+1+2(N-1)$.

The effective beam moment of inertia I_{ej} at increment j is determined using the method presented in *Design of Post-Tensioned Slabs*, published by the Post-Tensioning Institute, 1987, p. 15. In the PTI method, the effective moment of inertia I_{ej} at any increment j is related to the maximum service load flexural tensile stress which occurs at that increment. For maximum flexural tensile stress values f_{tj} less than or equal to $6\sqrt{f'_c}$:

$$I_{ej} = I_{gj}$$

For $f_{tj} > 6\sqrt{f'_c}$:

$$I_{ej} = I_{gj} \left[1 - 0.3 \left(\frac{\frac{f_{tj}}{\sqrt{f'_c}} - 6}{6} \right) \right] \leq 0.25 I_{gj}$$

where:

I_{gj} = Gross moment of inertia at segment j .

f_{tj} = Maximum flexural service load tensile stress at the center of segment j .

Moments M_j and m_{ji} and stresses f_{tj} for increment j are those which occur at the design point contained within increment j (design point j). Similarly the effective moment of inertia I_{ej} for segment j is based upon the gross moment of inertia I_{gj} at design point j .

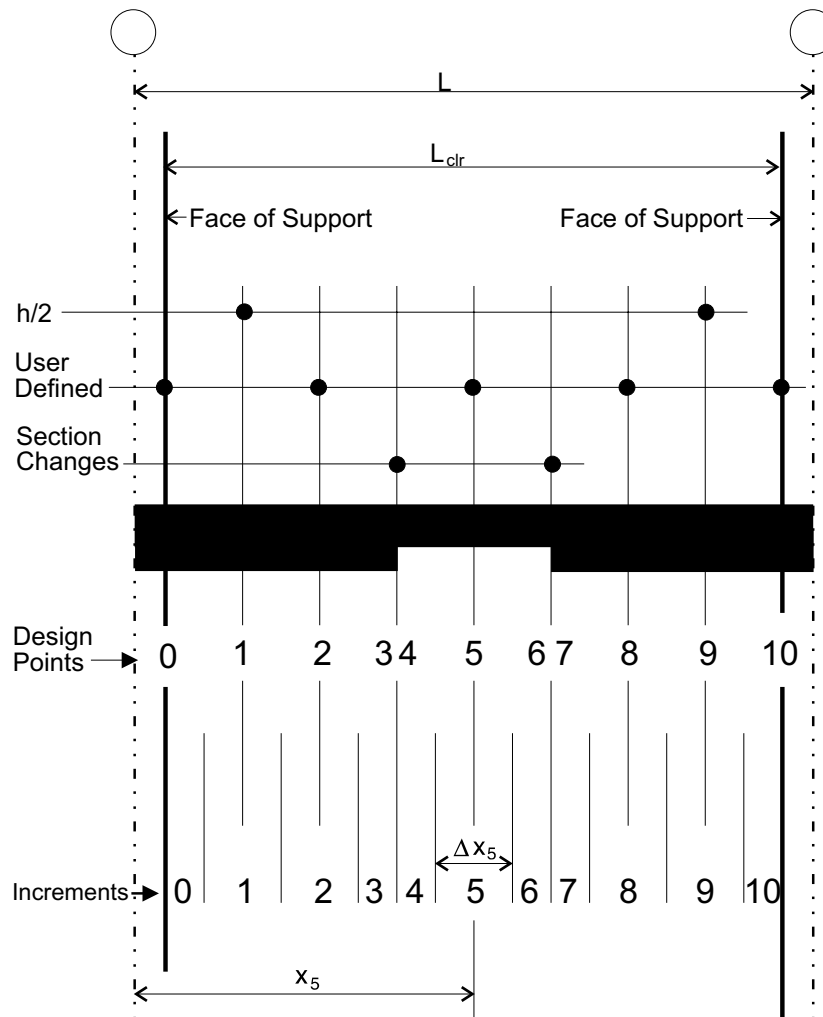

Figure 13.1 - Deflection Increments

The **PTData+** procedure outlined above is an extremely accurate non-linear method for calculating bending deflections. Moments of inertia of individual increments along the beam begin to reduce as the maximum flexural tensile stress at each increment exceeds $6\sqrt{f'_c}$. Thus the beam gets “soft” at points of high local flexural tension, a mathematical model which closely represents the actual deflection behavior of the beam under increasing load. Figure 13.2 shows a load deflection curve using data from actual **PTData+** runs for a symmetrical two-span beam designed to have a maximum flexural tensile stress of $6\sqrt{f'_c}$ under an applied live load of 50 psf. Applied live load in psf is plotted on the vertical axis against the maximum total load (DL+ w_{bal} +LL) deflection in inches at either midspan on the horizontal axis. As expected, the behavior is linear (elastic) for live load up to 50 psf; live load above 50 psf produces non-linear behavior.

The accuracy of the deflection calculations is a function of P , the number of user-defined spaces. For a simple-span beam with $B = 24''$ and $h = 48''$ spanning 60 feet, designed for a maximum flexural tensile stress less than $6\sqrt{f'_c}$ ($I_{ej} = I_{gj}$), an applied live load of 1.0 kip/foot produces an incremental midspan deflection of precisely:

$$\delta = \frac{5wL^4}{384EI} = \frac{5\left(\frac{1.0}{12}\right)(720)^4}{384 \times 3834 \times 221,184} = 0.344 \text{ in.}$$

With $P = 20$ **PTData+** calculates the equivalent deflection for this beam as 0.344", exactly correct. With $P = 10$ **PTData+** calculates the deflection as 0.345", within 0.29% of the exact value. With $P = 4$, **PTData+** calculates the deflection as 0.353",

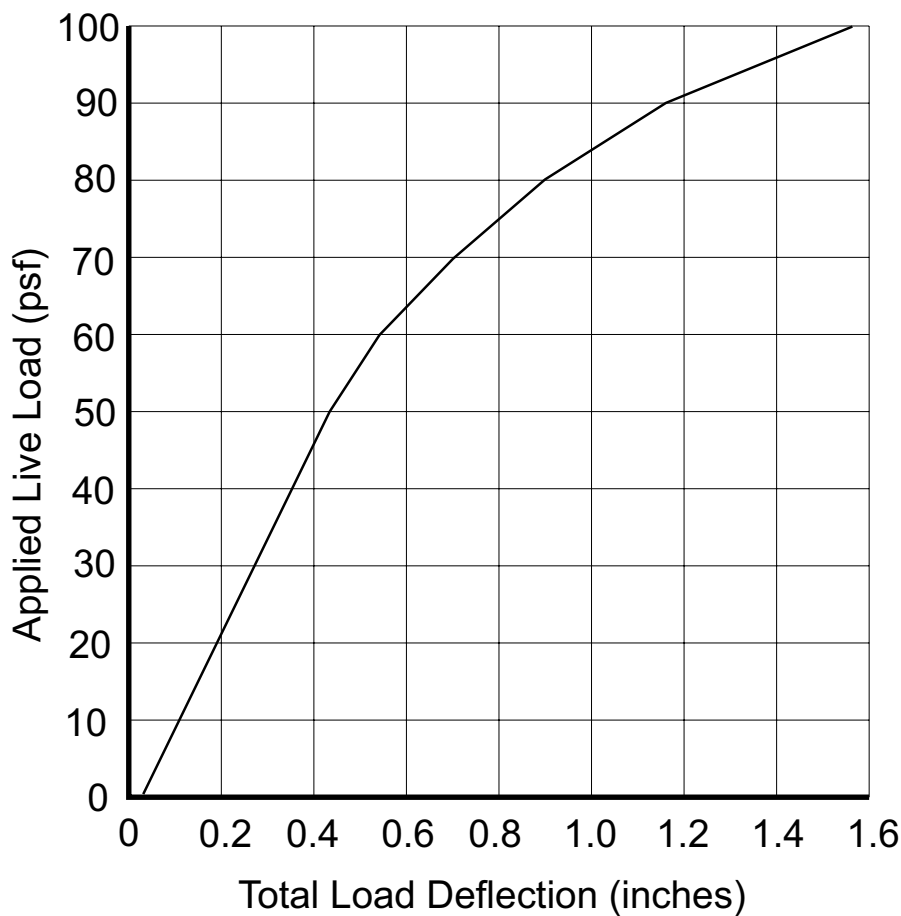

Figure 13.2 - Load-Deflection Curve

still within 2.33% of the exact value. Finally, with $P = 2$, **PTData+** calculates the deflection as 0.389", off by 13.1%. P values of 4 or greater should produce sufficiently accurate deflection values.

The user is cautioned not to confuse *calculated* deflection values with field measurements of apparent "deflection" in existing structures. The two often bear little resemblance. Construction factors beyond the control of the engineer can result in apparent deflections several times the value of actual bending deflections. These factors include form deflection and settlement, misplacement of reinforcing, low-strength or low-modulus concrete, improper tendon stressing, and others. It should be noted that ACI Code deflection limitations (ACI 318, Chapter 9) refer to *calculated* deflections, not *measured* deflections, which often reflect many factors other than bending.

This page intentionally left blank

Chapter Fourteen

Shear Strength

14.1 - Beam Shear

A complete beam shear analysis and design is done in conformance with ACI 318 Chapter 11 at each design point (see Chapter 8, Figure 8.1 for the definition of the design points). The Code states that the factored shear force at any beam section must be equal to or less than the useable shear capacity:

$$V_u \leq \phi V_n \quad \text{(Eqn. 14-1)}$$

where the nominal shear capacity V_n consists of two parts:

$$V_n = V_c + V_s \quad \text{(Eqn. 14-2)}$$

V_c is the nominal (calculated without a ϕ -factor) shear strength of the concrete alone and V_s is the nominal shear strength of the shear reinforcement (stirrups) alone. Thus both concrete and shear reinforcement contribute to the total calculated shear strength of a prestressed concrete beam.

In determining the terms V_u and M_u in beam shear calculations, the applied factored shear and moment at any section, **PTData+** uses the **largest possible shear** for V_u , and the moment associated with that largest shear for M_u . In shear calculations V_u and M_u do not include secondary shear and moment effects, i.e., they include just the factored dead, live, and wind loads. Inclusion of secondary moments and shears would have a negligible effect on shear calculations.

The Code Notation Section 11.0 defines d , a commonly used variable in shear calculations, as the “distance from extreme compression fiber to centroid of longitudinal tension reinforcement”. In **PTData+** shear calculations, however, d is conservatively measured from the extreme compression fiber to the centroid of the **prestressed reinforcement**.

14.1(a) - Concrete Shear Strength

The nominal concrete shear strength V_C is determined by calculating three shear capacities, each predicting the shear at which a unique type of concrete shear failure occurs in prestressed concrete beams:

- V_{cn} (ACI 318 Equation 11-10)
- V_{cw} (ACI 318 Equation 11-13)
- V_{ci} (ACI 318 Equation 11-11)

The *smaller* of V_{cw} and V_{ci} is compared to V_{cn} , and the *larger* of those two shear capacities is the *controlling* shear strength V_C . Following is a discussion of each of these three shear values:

14.1(a)1 - V_{cn} (ACI 318 Equation 11-10)

The V_{cn} equation is:

$$V_{cn} = \left(0.6\sqrt{f'_c} + 700 \frac{V_u d}{M_u} \right) B_w d \quad \text{(Eqn. 14-3)}$$

Equation 14-3 can always be used for V_C in lieu of the more rigorous V_{ci} and V_{cw} equations. As such, it normally, but not always, yields a conservative value for V_C , i.e., it is usually **smaller** than the **smaller** of V_{ci} and V_{cw} . In Equation 14-3 the term $V_u d / M_u$ has a maximum value of 1.0, and V_{cn} has a range of permissible values as follows:

$$2\sqrt{f'_c} B_w d \leq V_{cn} \leq 5\sqrt{f'_c} B_w d$$

The Code permits a minimum value of $0.8h$ for d in prestressed concrete shear calculations. However the Code defines d in the term $V_u d / M_u$ as the “distance from extreme compression fiber to centroid of prestressed reinforcement” and specifically does not mention an $0.8h$ minimum for **this** d . Thus, the $0.8h$ minimum which applies to the typical value of d in shear calculations apparently **does not apply** to this term. The d term outside the parenthesis in Equation 14-3, covered by the general

definition of d , *does* have an $0.8h$ minimum. Therefore, in an extraordinarily unusual example of code-writing, Equation 14-3 contains a single variable name, d , which can, and normally does, have two different values in the same equation.

14.1(a)2 - V_{cw} (ACI 318 Equation 11-13)

The “ w ” in V_{cw} stands for “web cracking”, a type of diagonal tension shear cracking which normally occurs at beam locations with large shears and small moments (for example, at a pinned exterior support). The equation which predicts the shear value at which this type of cracking occurs is:

$$V_{cw} = \left(3.5\sqrt{f'_c} + 0.3f_{pc}\right) B_w d + V_p \quad \text{(Eqn. 14-4)}$$

V_p is the vertical component of the prestressing force (the shear “carried” by the tendons) at the point being evaluated. In areas of tendon “reversed curvature”, which are normally critical shear areas, V_p is difficult (impossible?) to evaluate accurately.

PTData+ conservatively ignores the V_p term in Equation 14-4.

14.1(a)3 - V_{ci} (ACI 318 Equation 11-11)

The “ i ” in V_{ci} stands for “inclined cracking”, a type of shear failure which occurs at beam locations with large shears and moments (for example, at interior supports of continuous beams). The equation which predicts the shear value at which this type of failure occurs is:

$$V_{ci} = 0.6\sqrt{f'_c} B_w d + V_{dl} + \frac{V_i M_{cr}}{M_{\max}} \geq 1.7\sqrt{f'_c} B_w d \quad \text{(Eqn. 14-5)}$$

where:

$$M_{cr} = \frac{I}{y_t} \left(6\sqrt{f'_c} + f_{pe} - f_{dl}\right) \quad \text{(Eqn. 14-6)}$$

In evaluating Equation 14-6 it should be carefully noted that since f_{pe} is *defined* as a compressive stress, it is entered as a positive value if it is in fact compressive. If f_{pe} is found to be a tensile stress, it is entered into Equation 14-6 as a negative value. Similarly, f_{dl} is *defined* as a tensile stress, therefore it is always entered into Equation 14-6 as a positive value. In this instance, the sign convention for f_{pe} conflicts with the general **PTData+** sign convention which defines compressive stresses as negative. It is useful to note that the term I/y_t (the section modulus at the extreme beam fiber where tension is caused by applied loads) appears in three places in Equation

14-6; 1) outside the parenthesis, 2) in the f_{dl} term, and 3) in the f_{pe} term. It is exactly the same term (same numerical value taken at the same beam fiber) in all three places.

ACI 318 presents the designer with several conflicting definitions of V_i and M_{max} (see Notation Section 11.0, Commentary last paragraph on p.146, and Commentary top of p.147). The clearest definition appears on p.147, and is the one used by **PTData+**:

$$V_i = V_u - V_{dl}$$

$$M_{max} = M_u - M_{dl}$$

14.1(b) - Reinforcement Shear Strength

The nominal strength of vertical shear reinforcement in prestressed concrete beams is:

$$V_s = \frac{A_v f_y d}{s} \leq 8\sqrt{f'_c} B_w d \quad \text{(Eqn. 14-7)}$$

Combining Equations 14-1, 14-2, and 14-3 yields the equation for the required area of shear reinforcement per unit length of beam:

$$\frac{A_v}{s} = \frac{V_u - \phi V_c}{\phi f_y d} \quad \text{(Eqn. 14-8)}$$

From Equations 14-7 and 14-8 it is seen that V_s can also be expressed as:

$$V_s = \frac{V_u - \phi V_c}{\phi}$$

Also from Equation 14-8 it can be seen that shear reinforcement is not required to satisfy Equation 14-1 if:

$$V_u - \phi V_c \leq 0$$

In this case the nominal concrete strength alone is adequate to provide the required shear capacity without shear reinforcement.

14.1(c) - Minimums

The ACI Code requires a minimum amount of shear reinforcement (stirrups) in any prestressed concrete member where:

$$V_u > \frac{1}{2} \phi V_c$$

The following members are excepted from this requirement (there is *no minimum* stirrup requirement):

- Slabs and Footings
- Concrete joists as defined in ACI 318 Section 8.11
- Beams with a total depth h which is *smaller* than the *largest* of the following three quantities:
 - 10 inches
 - 2.5 times the flange thickness
 - One-half the web thickness.

In members where minimums *are* required, the minimum amount of shear reinforcement per unit length of beam is the *smaller* of the following two quantities:

$$\frac{A_v}{s} = \frac{50B_w}{f_y}$$

$$\frac{A_v}{s} = \frac{A_{ps}f_{pu}}{80f_y d} \sqrt{\frac{d}{B_w}}$$

14.1(d) - Maximum Stirrup Spacing

The Code places a limit on the maximum spacing of stirrups when they are required for any reason. These spacing limits insure that some stirrups cross every potential shear crack. These maximum spacing limits are independent of the stirrup size. For prestressed beams where stirrups provide a relatively small portion of the total shear strength, defined as:

$$V_s \leq 4\sqrt{f'_c} B_w d$$

the maximum stirrup spacing is $0.75h$ or 24", whichever is less. If stirrups provide a relatively large portion of the shear strength, defined as:

$$4\sqrt{f'_c}B_wds < V_s \leq 8\sqrt{f'_c}B_wd$$

the maximum spacings are cut in half, $0.375h$ or 12", whichever is less.

When no stirrups are required for strength at a particular design point ($A_v/s \leq 0$ in Eqn. 14-8) and no minimums apply (Section 14.1(c)), **PTData+** output data will show a 24" stirrup spacing for that point.

14.2 - Punching Shear

For 2-way systems **PTData+** performs a punching shear and moment transfer analysis at each slab-column joint. The ACI Code requires at each column that the total factored shear, and a portion of the unbalanced factored moment, be transferred from the equivalent frame slab-beam to the column through a section of slab concrete surrounding the column known as the "critical section". A critical section exists just outside the column and just outside each change in slab thickness in the vicinity of the column, i.e., at each drop cap. The critical section follows the column or drop cap plan shape and is located at a distance of $d/2$ from the edge of the column or drop cap. For punching shear analyses **PTData+** assumes that round columns are square columns with the same cross-sectional area. The shears and moments acting on the critical section produce stresses on the critical section and the Code limits these stresses to certain permissible values.

A minimum of one and a maximum of three critical sections are recognized at each joint which will permit the complete shear analysis of a joint with a double drop cap as shown in Figure 14.1. Critical section #1 in Figure 14.1 is just outside the column (inside the first drop cap). This critical section is *always* present (with no drops, the flat plate condition, it is the *only* critical section) and it is always analyzed. Critical sections #2 and #3 are just outside the first and second drops, respectively, and they are analyzed if they are present. **PTData+** supports different drop cap dimensions (in plan and in depth) and different top-of-slab elevations on either side of each joint.

14.2(a) - Shears and Moments

PTData+ calculates the extreme stresses on the critical section under the action of factored dead, live and wind shears and moments, and unfactored secondary moments. Two conditions are examined, from which the controlling (largest) stress is determined:

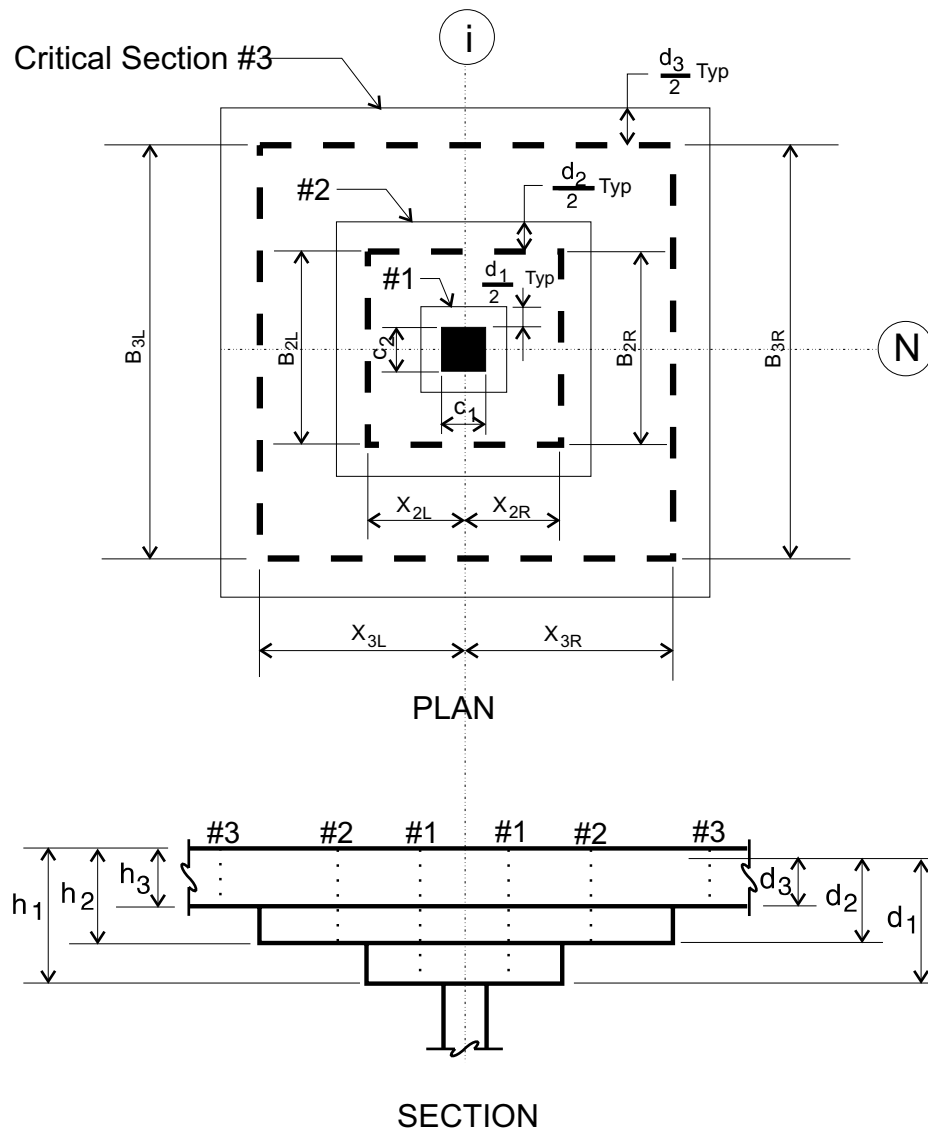

Figure 14.1 - Critical Punching Shear Sections

1. Maximum possible factored moment and the shear associated with that moment.
2. Maximum possible factored shear and the moment associated with that shear.

Shears in punching shear calculations (V_u) are those acting at the centerline of each column, considering continuity, due to factored loads. Moments in punching shear calculations (M_u) are those transferred from the slab to the column, at the column centerlines, due to factored loads (the “unbalanced” moments). The unbalanced moment is the difference in centerline beam end moments on either side of the joint.

The Code states that the unbalanced moment is transferred partly by direct flexure (in the contact area between slab and column) and partly by shear stresses on the critical section. Thus:

$$M_u = M_f + M_v$$

The *fraction* of the total unbalanced moment which must be transferred by shear stresses on the critical section is:

$$\gamma_v = 1 - \frac{1}{1 + \frac{2}{3} \sqrt{\frac{c_1 + d}{c_2 + d}}}$$

and the *moment* transferred by shear stresses on the critical section is:

$$M_v = \gamma_v M_u$$

Punching shear stress calculations assume the shear is applied at the centroid of the critical shear section, rather than at the centroid of the lower column. Figure 14.2 shows a freebody of an exterior joint including the columns (represented by a single lower column) and the portion of slab inside the critical section. Equilibrium of this

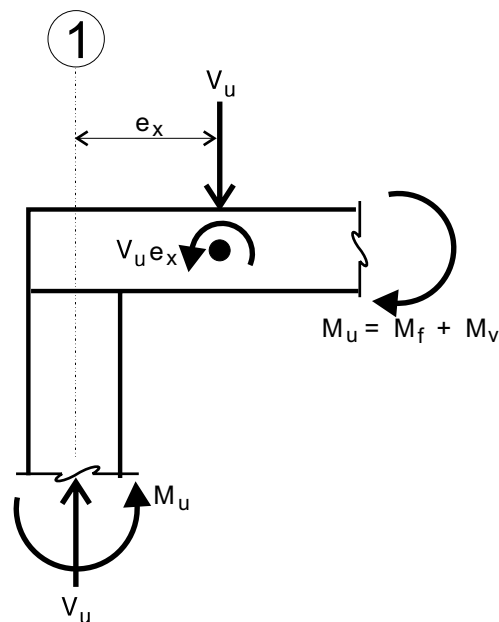

Figure 14.2 - Edge & Corner Columns

freebody requires a counterclockwise moment $V_u e_x$ which *reduces* the applied moment on the critical section. At edge and corner columns where the eccentricity between the column and critical section centroids is significant, **PTData+** adjusts the applied moment acting on the critical section as follows:

$$M_v = \gamma_v M_u - V_u e_x$$

14.2(b) - Applied and Allowable Stresses on the Critical Punching Shear Section

Applied stresses acting on the critical section are calculated using the following equation:

$$f_v = \frac{V_u}{A_c} \pm \frac{M_v x_c}{J_c}$$

where stresses acting *down* on the critical section are positive.

The allowable stress acting on the critical shear section is based upon the rather intricate requirements of ACI 318-89 Chapter 11. For *interior* columns (defined in 14.2(c)):

$$v_c = \phi \left(\beta_p \sqrt{f'_c} + 0.3f_{pc} \right) \tag{Eqn. 14-9}$$

where:

$$\beta_p = \frac{\alpha_s d}{b_o} + 1.5 \leq 3.5$$

The Code defines α_s as 40 for interior columns, 30 for edge (and edge parallel) columns, and 20 for corner columns. However in Section 11.12.2.2(a) it also states that “no portion of the column cross section shall be closer to a discontinuous edge than 4 times the slab thickness..” which effectively limits the use of Equation 14-9 to interior columns. Thus the α_s specifications for edge and corner columns are meaningless *in this equation* since they can never be used. In calculating f_{pc} **PTData+** averages the actual compression values acting on the left and right sides of the joint, and then averages *that* value with an assumed minimum 125 psi acting in the perpendicular direction (the top and bottom sides). In determining d/b_o **PTData+** uses the average d value for the entire critical section (A_c / b_o).

For edge, edge parallel, and corner columns, as defined in 14.2(c), v_c is the *smallest* of:

$$v_c = \phi \left(2 + \frac{4}{\beta_c} \right) \sqrt{f'_c}$$

$$v_c = \phi \left(\frac{\alpha_s d}{b_o} + 2 \right) \sqrt{f'_c}$$

and

$$v_c = \phi 4 \sqrt{f'_c}$$

14.2(c) - Critical Punching Shear Section Dimensions

Figure 14.3 shows the generalized **PTData+** punching shear critical section at each column. The general critical section consists of a maximum of six rectangular pieces as shown. The dimensions of each piece are a function of 1) the dimensions of the column, slab, and drop panels, and 2) the column type. **PTData+** recognizes four column types:

- **Edge** - a column at Joint 1 or S+1 where 1) the adjacent cantilever span is less than or equal to 4 times the smallest cantilever slab thickness plus the dimension from the centerline of the column to the edge of the first cantilever drop, if any, **and** 2) both *TRIBL* and *TRIBR* dimensions are greater than zero.
- **Corner** - a column at Joint 1 or S+1 where 1) the adjacent cantilever span is less than or equal to 4 times the smallest cantilever slab thickness plus the dimension from the centerline of the column to the edge of the first cantilever drop, if any, **and** 2) either *TRIBL* or *TRIBR* is zero.
- **Edge Parallel** - a column at Joints 2 through S where either *TRIBL* or *TRIBR* is zero **or** a column at Joint 1 or S+1 where either *TRIBL* or *TRIBR* is zero **and** the adjacent cantilever span is greater than 4 times the smallest cantilever slab thickness plus the dimension from the centerline of the column to the edge of the first cantilever drop, if any.
- Interior - all other columns.

Dimensions of the pieces of the critical section for all possible conditions recognized by **PTData+** are as follows (refer to Figures 14.1 and 14.3). For convenience, pieces 3 and 4 together are referred to as the “top” face of the critical section; pieces 1 & 2

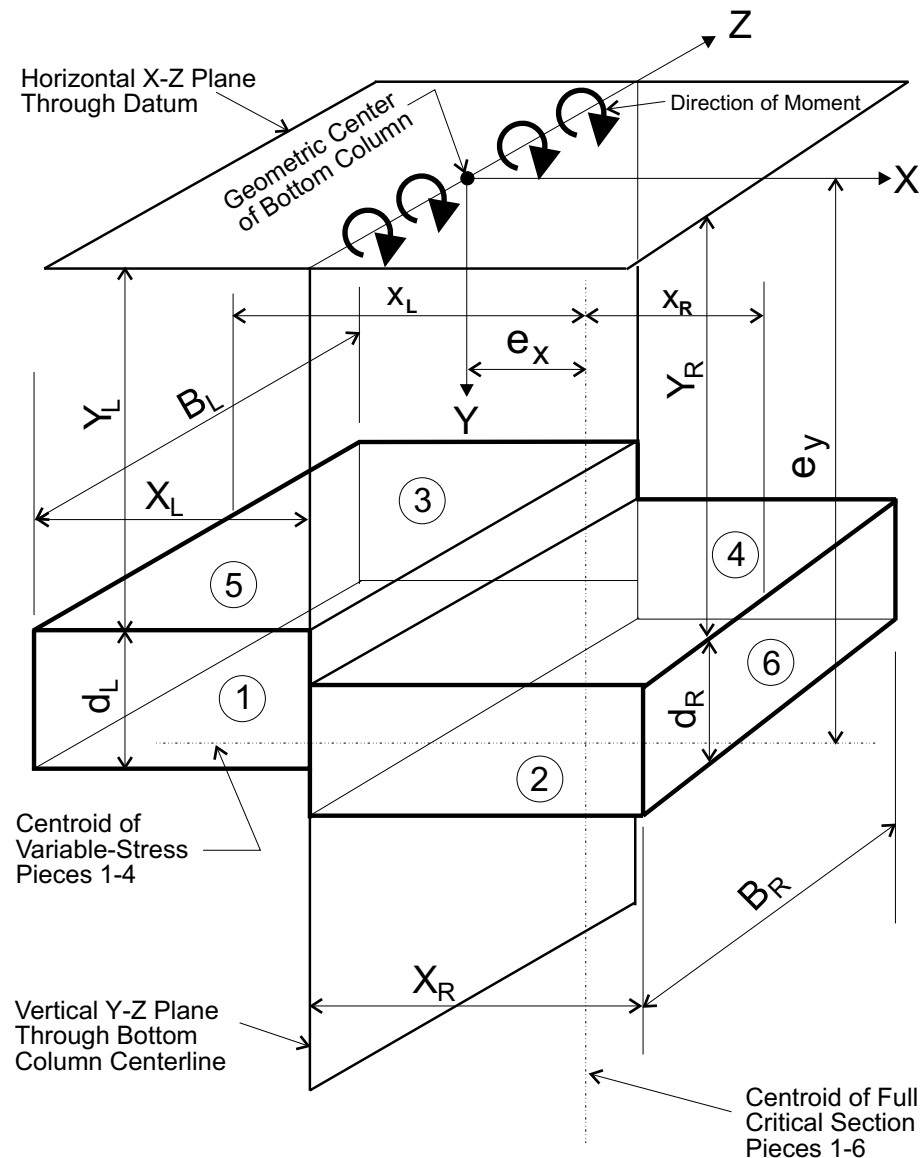

Figure 14.3 - Generalized Critical Section

the “bottom” face; piece 5 the “left” face; and piece 6 the “right” face. When both top face and bottom face are present, their dimensions are identical. In all cases the depth of the pieces (d_L & d_R) are based on the slab depth of the left and right faces respectively (pieces 5 and 6), In other words, the depth of pieces 2, 4 & 6 are all based upon the depth of slab associated with piece 6 (d_R); the depth of pieces 1, 3, & 5 are all based upon the depth of slab associated with piece 5 (d_L):

1. **Interior** - 4-sided with all 6 pieces present:

For Critical Section #1

$$B_L = c_2 + d_L : X_L = \frac{c_1 + d_L}{2}$$

$$B_R = c_2 + d_R : X_R = \frac{c_1 + d_R}{2}$$

For Critical Section #2

$$B_L = B_{2L} + d_L : X_L = X_{2L} + \frac{d_L}{2}$$

$$B_R = B_{2R} + d_R : X_R = X_{2R} + \frac{d_R}{2}$$

For Critical Section #3

$$B_L = B_{3L} + d_L : X_L = X_{3L} + \frac{d_L}{2}$$

$$B_R = B_{3R} + d_R : X_R = X_{3R} + \frac{d_R}{2}$$

2. **Left Edge** (at Joint 1) - 3-sided with all pieces present except piece 5:

For Critical Section #1

$$B_L = 0 : X_L = \frac{c_1}{2} : d_L = d_R$$

$$B_R = c_2 + d_R : X_R = \frac{c_1 + d_R}{2}$$

For Critical Section #2

$$B_L = 0 : X_L = \frac{c_1}{2} : d_L = d_R$$

$$B_R = B_{2R} + d_R : X_R = X_{2R} + \frac{d_R}{2}$$

For Critical Section #3

$$B_L = 0 : X_L = \frac{c_1}{2} : d_L = d_R$$

$$B_R = B_{3R} + d_R : X_R = X_{3R} + \frac{d_R}{2}$$

3. **Right Edge** (at Joint S+1) - 3 sided with all pieces present except piece 6:

For Critical Section #1

$$B_L = c_2 + d_L : X_L = \frac{c_1 + d_L}{2}$$

$$B_R = 0 : X_R = \frac{c_1}{2} : d_R = d_L$$

For Critical Section #2

$$B_L = B_{2L} + d_L : X_L = X_{2L} + \frac{d_L}{2}$$

$$B_R = 0 : X_R = \frac{c_1}{2} : d_R = d_L$$

For Critical Section #3

$$B_L = B_{3L} + d_L : X_L = X_{3L} + \frac{d_L}{2}$$

$$B_R = 0 : X_R = \frac{c_1}{2} : d_R = d_L$$

4. **Left Corner** (at Joint 1) - 2-sided with pieces 1, 2, and 6 if *TRIBL* is present or pieces 3, 4, and 6 if *TRIBR* is present:

For Critical Section #1

$$B_L = 0 : X_L = \frac{c_1}{2} : d_L = d_R$$

$$B_R = c_2 + \frac{d_R}{2} : X_R = \frac{c_1 + d_R}{2}$$

For Critical Section #2

$$B_L = 0 : X_L = \frac{c_1}{2} : d_L = d_R$$

$$B_R = B_{2R} + \frac{d_R}{2} : X_R = X_{2R} + \frac{d_R}{2}$$

For Critical Section #3

$$B_L = 0 : X_L = \frac{c_1}{2} : d_L = d_R$$

$$B_R = B_{3R} + \frac{d_R}{2} : X_R = X_{3R} + \frac{d_R}{2}$$

5. **Right Corner** (at Joint S+1) - 2-sided with pieces 1, 2, and 5 if *TRIBL* is present or pieces 3, 4, and 5 if *TRIBR* is present:

For Critical Section #1

$$B_L = c_2 + \frac{d_L}{2} : X_L = \frac{c_1 + d_L}{2}$$

$$B_R = 0 : X_R = \frac{c_1}{2} : d_R = d_L$$

For Critical Section #2

$$B_L = B_{2L} + \frac{d_L}{2} : X_L = X_{2L} + \frac{d_L}{2}$$

$$B_R = 0 : X_R = \frac{c_1}{2} : d_R = d_L$$

For Critical Section #3

$$B_L = B_{3L} + \frac{d_L}{2} : X_L = X_{3L} + \frac{d_L}{2}$$

$$B_R = 0 : X_R = \frac{c_1}{2} : d_R = d_L$$

6. **Edge Parallel** - 3-sided with pieces 1, 2, 5, and 6 if *TRIBL* is present or pieces 3, 4, 5, and 6 if *TRIBR* is present:

For Critical Section #1

$$B_L = c_2 + \frac{d_L}{2} : X_L = \frac{c_1 + d_L}{2}$$

$$B_R = c_2 + \frac{d_R}{2} : X_R = \frac{c_1 + d_R}{2}$$

For Critical Section #2

$$B_L = B_{2L} + \frac{d_L}{2} : X_L = X_{2L} + \frac{d_L}{2}$$

$$B_R = B_{2R} + \frac{d_R}{2} : X_R = X_{2R} + \frac{d_R}{2}$$

For Critical Section #3

$$B_L = B_{3L} + \frac{d_L}{2} : X_L = X_{3L} + \frac{d_L}{2}$$

$$B_R = B_{3R} + \frac{d_R}{2} : X_R = X_{3R} + \frac{d_R}{2}$$

14.2(d) - Critical Punching Shear Section Properties

The critical section properties are ($K = 1$ for corner and edge parallel columns; $K = 2$ for all other columns):

Area of the entire critical section:

$$A_c = B_L d_L + B_R d_R + K(X_L d_L + X_R d_R)$$

Area of **one** entire variable stress side (the top **or** bottom face):

$$A_{side} = X_L d_L + X_R d_R$$

Horizontal distance from column centerline to centroid of the entire critical section:

$$e_x = \frac{B_R d_R X_R - B_L d_L X_L + K\left(d_R \frac{X_R^2}{2} - d_L \frac{X_L^2}{2}\right)}{A_c}$$

Vertical distance from datum to centroid of variable-stress sides:

$$e_y = \frac{X_R d_R \left(Y_R + \frac{d_R}{2}\right) + X_L d_L \left(Y_L + \frac{d_L}{2}\right)}{A_{side}}$$

Polar moment of inertia of entire critical section:

$$J_c = B_R d_R (X_R - e_x)^2 + B_L d_L (X_L + e_x)^2$$

$$+ K \left[X_R d_R \left(\frac{X_R}{2} - e_x\right)^2 + X_L d_L \left(\frac{X_L}{2} + e_x\right)^2 + \frac{d_R X_R^3}{12} + \frac{d_L X_L^3}{12} \right]$$

$$+ K \left[X_R d_R \left(Y_R + \frac{d_R}{2} - e_y\right)^2 + X_L d_L \left(Y_L + \frac{d_L}{2} - e_y\right)^2 + \frac{X_R d_R^3}{12} + \frac{X_L d_L^3}{12} \right]$$

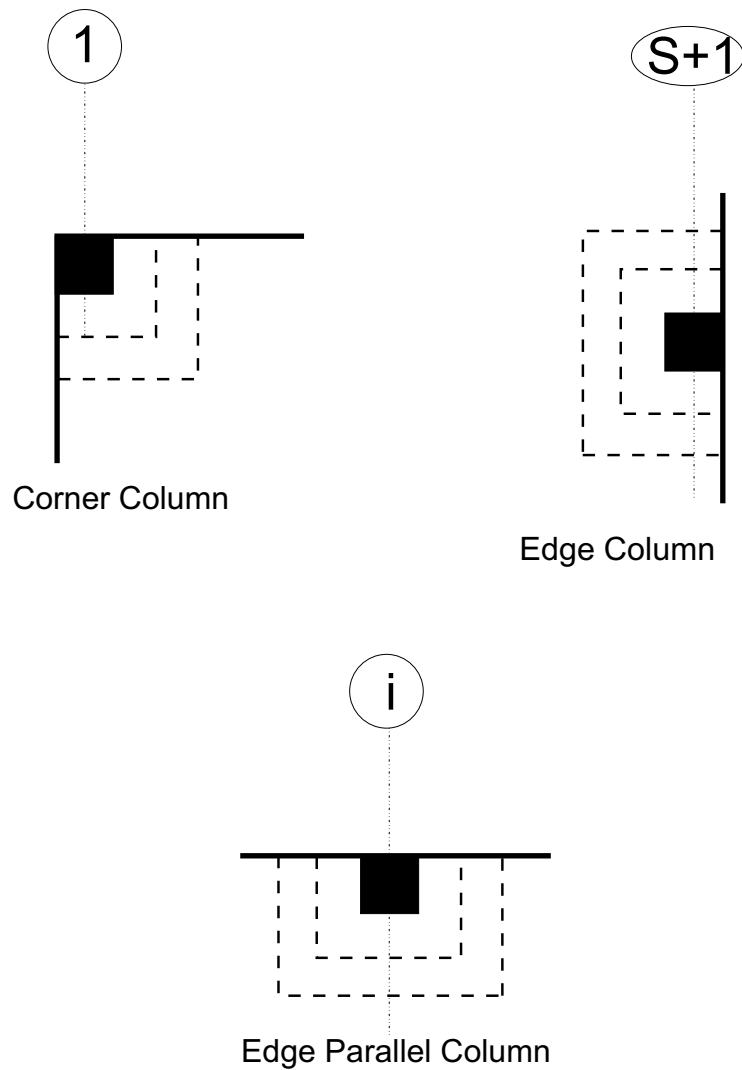

Figure 14.4 - Column & Slab Edge Relationships

14.2(e) - Column & Slab Edge Relationships

For punching shear calculations at edge, corner, and edge parallel column conditions **PTData+** assumes the slab edges to be flush with the column faces as shown in Figure 14.4. If the actual relationship between the slab edges and the columns are different from those shown in Figure 14.4, the designer must verify the adequacy of the shear calculations at those locations.

14.2(f) - The “d” Dimension in Punching Shear Calculations

For punching shear calculations **PTData+** assumes that the “centroid of the resultant total tension force” is at the centroid of two perpendicular post-tensioned tendons

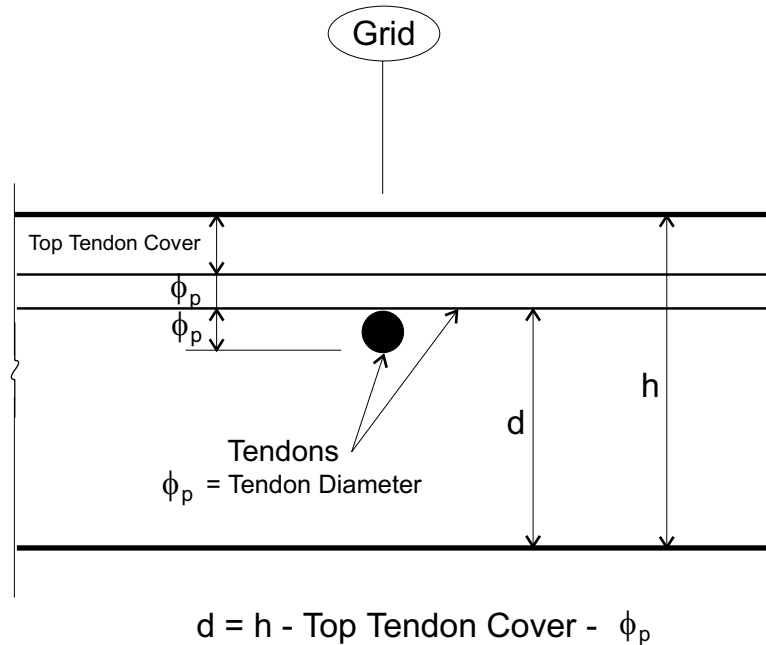

Figure 14.5 - The “d” Dimension in Punching Shear Calculations

which cross at the center of the column. The dimension from the top of the slab to this point is equal to the top tendon cover plus one tendon diameter (p). The d dimension is:

$$d = h - (\text{Top Tendon Cover}) - \phi_p$$

This is shown in Figure 14.5. *Note that d need not be taken as less than $0.8h$.*